

RAMPE DI CARICO

Soluzioni di carico e scarico su misura



Rampe di Carico WM

Le nostre rampe sono progettate per adattarsi alle operazioni di carico e scarico, rispondendo alle esigenze del tuo veicolo e del tuo settore.



11 MODELLI DI RAMPE UNICHE

Realizzate in alluminio e ferro di alta qualità e progettate in Italia, le nostre rampe di carico offrono soluzioni modulari e personalizzabili, pensate per garantire sicurezza, durabilità e prestazioni ottimali.

LE NOSTRE RAMPE

TUTTE LE RAMPE HANNO



Tutte le nostre rampe sono certificate TÜV



Omologazione non necessaria



100% Made in Italy



2 anni di garanzia

PERCHÈ SCEGLIERE LE NOSTRE RAMPE

Flessibilità:

Una gamma completa di rampe manuali per ogni settore e necessità;

Qualità:

Garantita da processi di produzione interni (Saldatura e lavorazioni CNC) che assicurano robustezza e durata;

Risparmio di tempo:

L'operatore può caricare e scaricare in autonomia;

Sicurezza:

Le rampe migliorano le condizioni di lavoro riducono i rischi operativi;

**CON OLTRE 100 RIVENDITORI IN TUTTO IL MONDO,
LE NOSTRE SOLUZIONI SONO OVUNQUE NE HAI BISOGNO.**

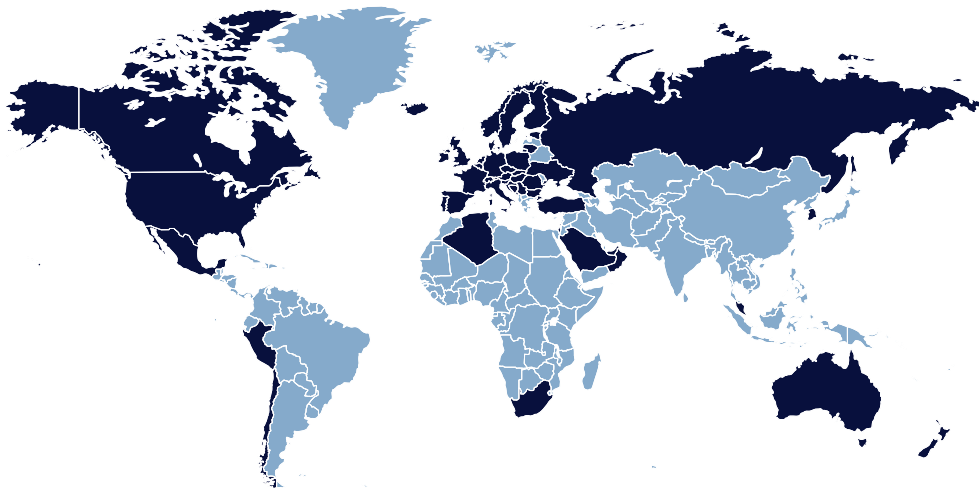

WM PC

DESCRIZIONE:

Rampa di carico semplice, robusta e ruotabile. Adatta a carichi pesanti con portata da 600 kg a 1800 kg per veicoli commerciali leggeri.



CARATTERISTICHE



Portata:

da 600kg a 1800kg



Movimentazione:

Rotazione esterna e interna



Dimensioni personalizzate:

Larg. da 60 a 137,5 cm,

Lung. da 195 a 325 cm

- Piano in alluminio mandorlato antiscivolo
- Ruota per apertura facilitata
- Piedini di sostegno
- Bandella mobile di raccordo al piano

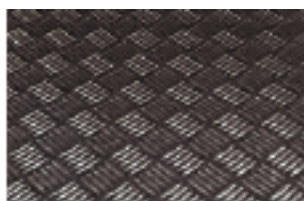

APERTURA E CHIUSURA:

Doppio sistema di apertura/chiusura brevettato: orizzontale per carico/scarico e verticale per liberare il vano di carico e l'accesso al furgone. Il sistema a molle bilancia il peso, rendendo la rampa leggera e sicura da maneggiare in autonomia.

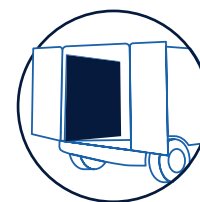
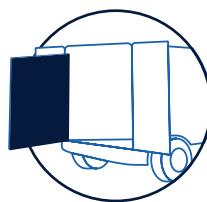
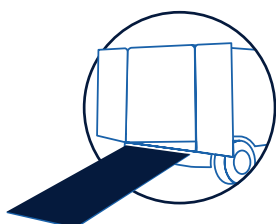
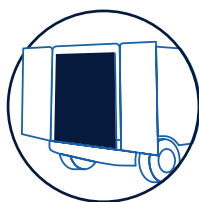

WM PC

ESEMPI DI POSSIBILI CONFIGURAZIONI

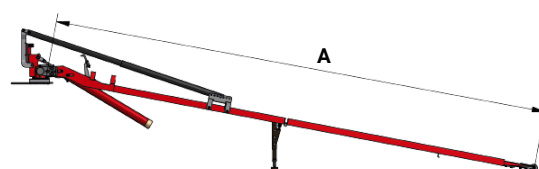
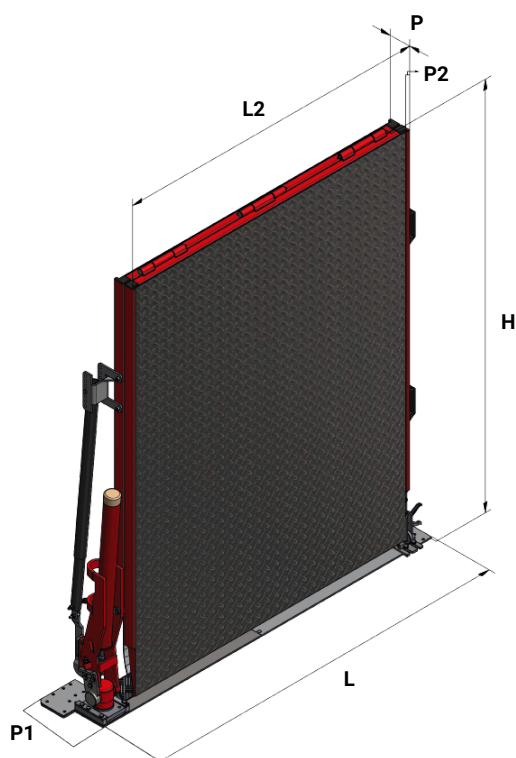

L2 (mm)	A (mm)	L (mm)	H (mm)	P (mm)	P1 (mm)	P2 (mm)	Capac. (Kg)	Peso* (Kg)
900	2200	1165	1215	95	250	8	600	81
950	2500	1215	1365	95	250	8	600	88
1000	3000	1265	1615	95	250	8	1000	106
1000	3250	1265	1740	95	250	8	1500	124
1050	2700	1315	1515	95	250	8	600	96
1100	3000	1365	1615	95	250	8	1500	131
1100	2500	1365	1365	95	250	8	1000	106
1200	2700	1465	1465	95	250	8	1000	117
1200	3250	1465	1740	95	250	8	1500	148
1250	2800	1515	1515	95	250	8	1000	128
1250	3000	1515	1615	95	250	8	1500	145
1300	3000	1565	1615	95	250	8	1000	139
1300	3250	1565	1740	95	250	8	1500	159
1350	3200	1615	1715	95	250	8	1500	160
1350	3250	1615	1740	95	250	8	1800	171

* Il peso non comprende il kit di montaggio, che dipende dal furgone. (min. 2 Kg - max. 7 Kg)

WM PC

OPTIONAL



GANCIO DI FISSAGGIO INTERNO

Gancio utilizzabile per bloccare la rampa in posizione completamente ruotata all'interno del veicolo.



KIT SUPPLEMENTARE - 3° PEZZO

Riduce l'angolo di inclinazione per rampe pieghevoli in 3 pezzi, ideale per veicoli piccoli. Disponibile per portate fino a 1.000 kg.

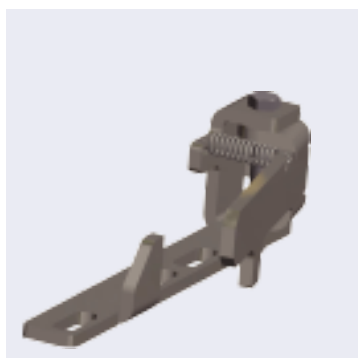

KIT ANTIVENTO

Fissa la rampa in posizione completamente ruotata all'esterno, prevenendo che raffiche di vento possano farla muovere e causare urti a persone o cose.



KIT ALLUNGAMENTO AMOVIBILE

Terzo pezzo rimovibile con ruote, da integrare alla rampa per estenderne la lunghezza. Adatto per portate fino a 1500 kg.

WM PC



WM ME

DESCRIZIONE:

Rampa di carico semplice e robusta adatta a carichi pesanti con portata da 600 kg a 1800 kg per veicoli commerciali leggeri.



CARATTERISTICHE



Portata:
da 600kg a 1800kg



Movimentazione:
Apertura in senso orizzontale



Dimensioni personalizzate:
Larg. da 60 a 137,5 cm,
Lung. da 195 a 325 cm

- Piano in alluminio mandorlato antiscivolo
- Ruota per apertura facilitata
- Piedini di sostegno
- Bandella mobile di raccordo al piano

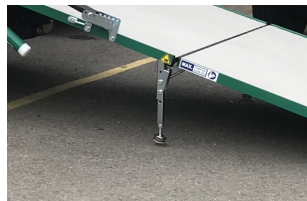
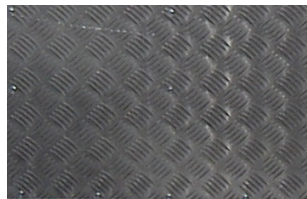

APERTURA E CHIUSURA:

La rampa è composta da due sezioni orizzontali, che si aprono e si chiudono con facilità. Il sistema a molle bilancia il peso. Su richiesta è disponibile la versione con molle su entrambi i lati, per un'apertura ancora più semplice.

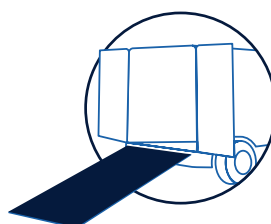
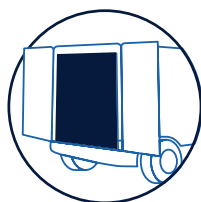
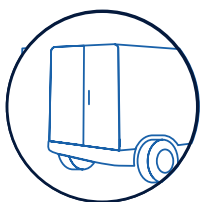

WM ME

ESEMPI DI POSSIBILI CONFIGURAZIONI

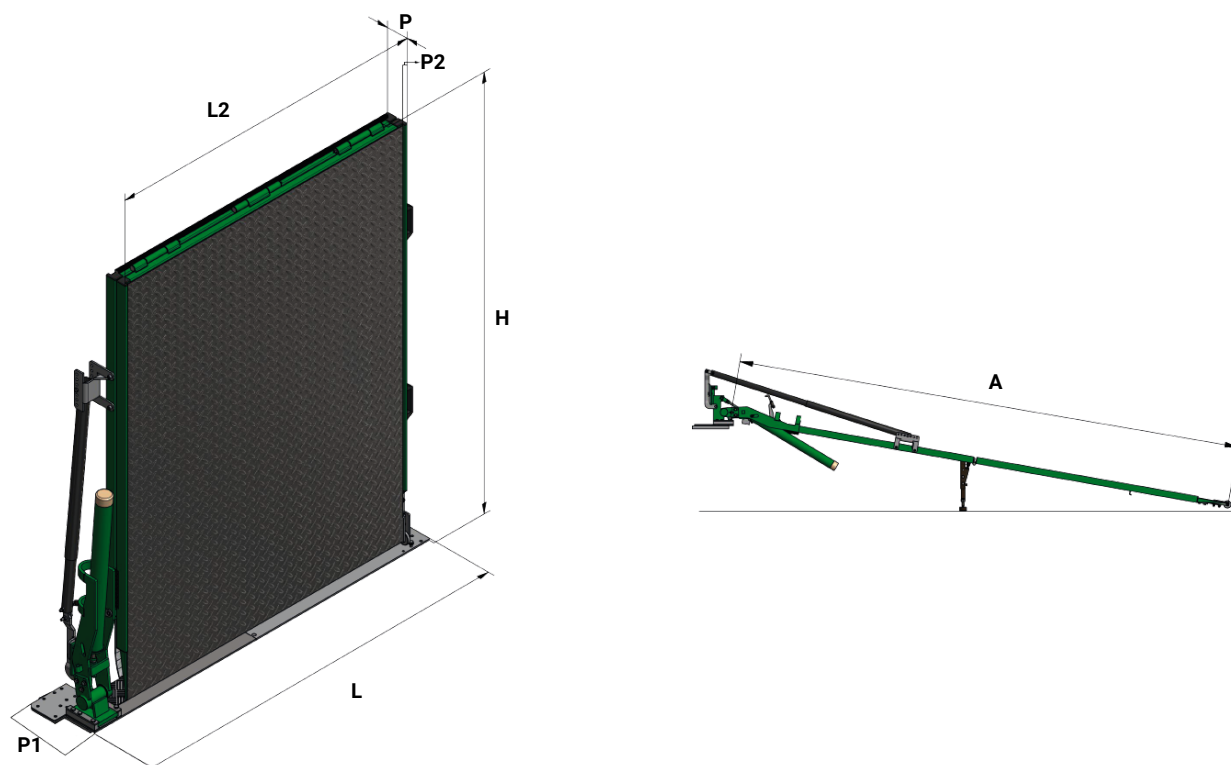

L2 (mm)	A (mm)	L (mm)	H (mm)	P (mm)	P1 (mm)	P2 (mm)	Capac. (Kg)	Peso* (Kg)
900	2200	1165	1215	95	250	8	600	79
950	2500	1215	1365	95	250	8	600	86
1000	3000	1265	1615	95	250	8	1000	104
1000	3250	1265	1740	95	250	8	1500	122
1050	2700	1315	1515	95	250	8	600	94
1100	3000	1365	1615	95	250	8	1500	129
1100	2500	1365	1365	95	250	8	1000	104
1200	2700	1465	1465	95	250	8	1000	115
1200	3250	1465	1740	95	250	8	1500	146
1250	2800	1515	1515	95	250	8	1000	126
1250	3000	1515	1615	95	250	8	1500	143
1300	3000	1565	1615	95	250	8	1000	137
1300	3250	1565	1740	95	250	8	1500	157
1350	3200	1615	1715	95	250	8	1500	158
1350	3250	1615	1740	95	250	8	1800	169

* Il peso non comprende il kit di montaggio, che dipende dal furgone. (min. 2 Kg - max. 7 Kg)

WM ME

OPTIONAL



KIT RUOTA

Studiato per agevolare l'apertura e chiusura della rampa, facilitandone la movimentazione. Disponibile su richiesta anche per il lato sinistro. Ruota opzionale da fissare alla/e estremità.

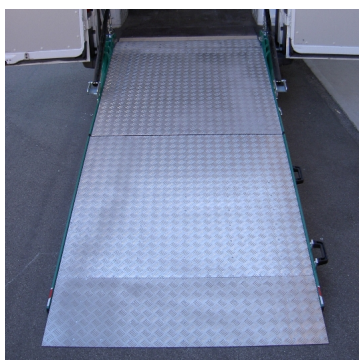

KIT SUPPLEMENTARE - 3° PEZZO

Riduce l'angolo di inclinazione per rampe pieghevoli in 3 pezzi, ideale per veicoli piccoli. Disponibile per portate fino a 1.000 kg.



BORDI LATERALI RIPIEGHEVOLI

Bordi laterali anticaduta in alluminio per aumentare la sicurezza in certi contesti di utilizzo.



KIT ALLUNGAMENTO AMOVIBILE

Terzo pezzo rimovibile con ruote, da integrare alla rampa per estenderne la lunghezza. Adatto per portate fino a 1500 kg.

WM ME



WM PC-R

DESCRIZIONE:

Rampa di carico con piano antiscivolo in rete forata, adatta ad attrezzature con grandi ruote gommate.



CARATTERISTICHE



Portata:
500kg



Movimentazione:
Rotazione esterna e interna



Dimensioni personalizzate:
Larg. da 60 a 137,5 cm,
Lung. da 195 a 325 cm

- Piano antiscivolo retato
- Ruota per apertura facilitata
- Piedini di sostegno
- Bandella mobile di raccordo al piano

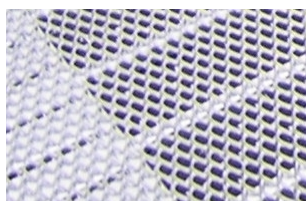

APERTURA E CHIUSURA:

Doppio sistema di apertura/chiusura brevettato: orizzontale per carico/scarico e verticale per liberare il vano di carico e l'accesso al furgone. Il sistema a molle bilancia il peso, rendendo la rampa leggera e sicura da maneggiare in autonomia.

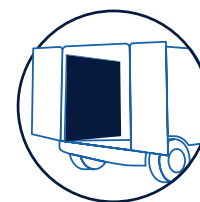
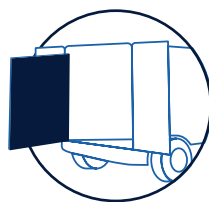
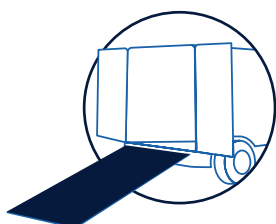
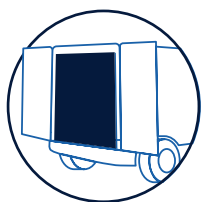

WM PC-R

ESEMPI DI POSSIBILI CONFIGURAZIONI

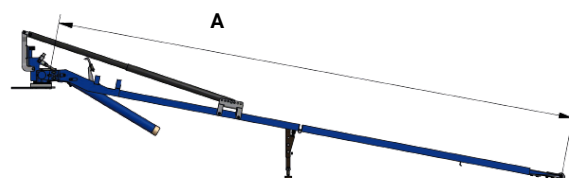
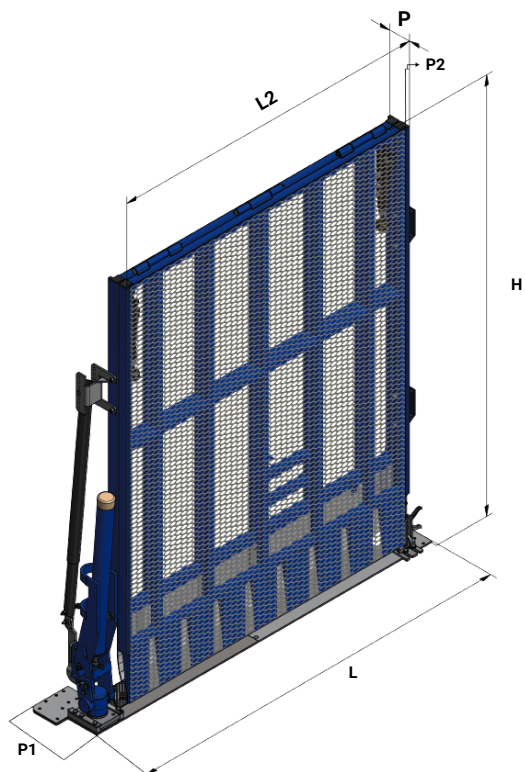

L2 (mm)	A (mm)	L (mm)	H (mm)	P (mm)	P1 (mm)	P2 (mm)	Capac. (Kg)	Peso* (Kg)
900	2200	1165	1215	95	250	8	500	81
950	2500	1215	1365	95	250	8	500	88
1000	3000	1265	1615	95	250	8	500	106
1000	3250	1265	1740	95	250	8	500	124
1050	2700	1315	1515	95	250	8	500	96
1100	3000	1365	1615	95	250	8	500	131
1100	2500	1365	1365	95	250	8	500	106
1200	2700	1465	1465	95	250	8	500	117
1200	3250	1465	1740	95	250	8	500	148
1250	2800	1515	1515	95	250	8	500	128
1250	3000	1515	1615	95	250	8	500	145
1300	3000	1565	1615	95	250	8	500	139
1300	3250	1565	1740	95	250	8	500	159
1350	3200	1615	1715	95	250	8	500	160
1350	3250	1615	1740	95	250	8	500	171

* Il peso non comprende il kit di montaggio, che dipende dal furgone. (min. 2 Kg - max. 7 Kg)

WM PC-R

OPTIONAL



BORDI LATERALI RIPIEGHEVOLI

Bordi laterali anticaduta in alluminio per aumentare la sicurezza in certi contesti di utilizzo.



KIT SUPPLEMENTARE - 3° PEZZO

Riduce l'angolo di inclinazione per rampe pieghevoli in 3 pezzi, ideale per veicoli piccoli. Disponibile per portate fino a 500 kg.



PIEDI SPECIALI

In caso di macchinari molto bassi da terra sono disponibili i piedi speciali che creano due inclinazioni diverse del piano, favorendone la salita.



KIT RUOTA

Studiato per agevolare l'apertura e chiusura della rampa, facilitandone la movimentazione. È standard sul lato destro, disponibile come optional per il lato sinistro.

WM PC-R



WM ME-R

DESCRIZIONE:

Rampa di carico con piano antiscivolo in rete forata, adatta ad attrezzature con grandi ruote gommate.



CARATTERISTICHE



Portata:
500kg



Movimentazione:
Apertura in senso orizzontale



Dimensioni personalizzate:
Larg. da 60 a 137,5 cm,
Lung. da 195 a 325 cm

- Piano antiscivolo retato
- Ruota per apertura facilitata
- Piedini di sostegno
- Bandella mobile di raccordo al piano

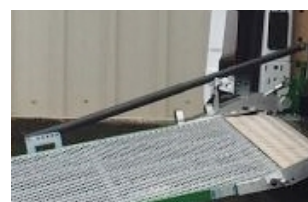

APERTURA E CHIUSURA:

La rampa si apre e si chiude in due parti in senso orizzontale. Il sistema di molle bilancia il peso della rampa e la rende leggera durante le operazioni di apertura e chiusura, permettendo a chiunque di maneggiare la rampa in sicurezza.

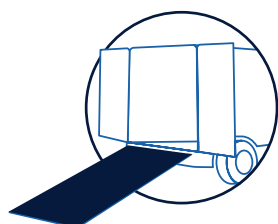
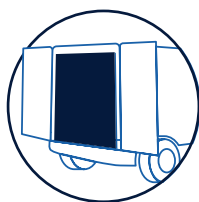

WM ME-R

ESEMPI DI POSSIBILI CONFIGURAZIONI

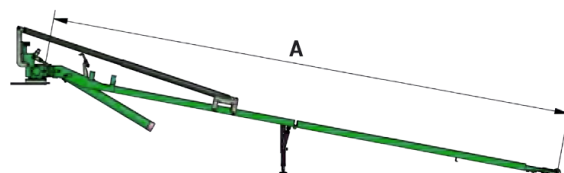
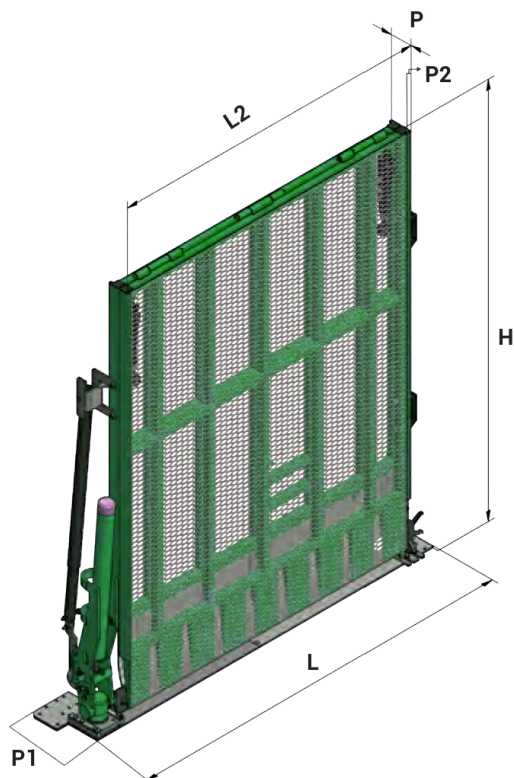

L2 (mm)	A (mm)	L (mm)	H (mm)	P (mm)	P1 (mm)	P2 (mm)	Capac. (Kg)	Peso* (Kg)
900	2200	1165	1215	95	250	8	600	81
950	2500	1215	1365	95	250	8	600	88
1000	3000	1265	1615	95	250	8	1000	106
1000	3250	1265	1740	95	250	8	1500	124
1050	2700	1315	1515	95	250	8	600	96
1100	3000	1365	1615	95	250	8	1500	131
1100	2500	1365	1365	95	250	8	1000	106
1200	2700	1465	1465	95	250	8	1000	117
1200	3250	1465	1740	95	250	8	1500	148
1250	2800	1515	1515	95	250	8	1000	128
1250	3000	1515	1615	95	250	8	1500	145
1300	3000	1565	1615	95	250	8	1000	139
1300	3250	1565	1740	95	250	8	1500	159
1350	3200	1615	1715	95	250	8	1500	160
1350	3250	1615	1740	95	250	8	1800	171

* Il peso non comprende il kit di montaggio, che dipende dal furgone. (min. 2 Kg - max. 7 Kg)

WM ME-R

OPTIONAL



BORDI LATERALI RIPIEGHEVOLI

Bordi laterali anticaduta in alluminio per aumentare la sicurezza in certi contesti di utilizzo.

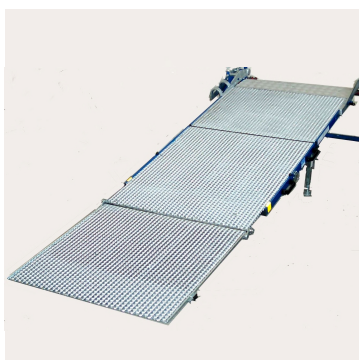

KIT SUPPLEMENTARE - 3° PEZZO

Riduce l'angolo di inclinazione per rampe pieghevoli in 3 pezzi, ideale per veicoli piccoli. Disponibile per portate fino a 500 kg.



PIEDI SPECIALI

In caso di macchinari molto bassi da terra sono disponibili i piedi speciali che creano due inclinazioni diverse del piano, favorendone la salita.



KIT RUOTA

Studiato per agevolare l'apertura e chiusura della rampa, facilitandone la movimentazione. È standard sul lato destro, disponibile come optional per il lato sinistro.

WM ME-R

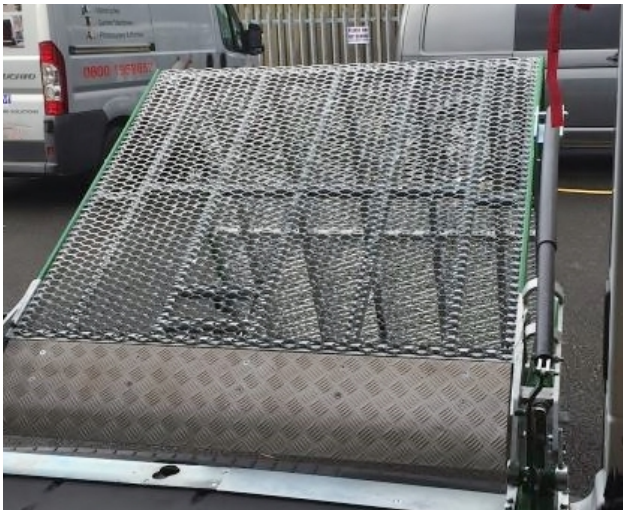

WM LIGHT PLUS

DESCRIZIONE:

Rampa di carico in alluminio leggera e resistente, per carichi fino a 600 Kg. Dotata di rotazione esterna per accedere velocemente al vano.



CARATTERISTICHE



Portata:

400 kg e 600 kg



Movimentazione:

Rotazione esterna



Dimensioni personalizzate:

Larg. da 40 a 120 cm,

Lung. da 175 a 325 cm

- Piano in alluminio anodizzato antiscivolo
- Ruote per apertura facilitata
- Bandella mobile che raccorda al piano
- Bordi laterali anti caduta (6 cm)



APERTURA E CHIUSURA:

Doppio sistema di apertura/chiusura brevettato: orizzontale per carico/scarico e verticale per liberare il vano di carico e l'accesso al furgone. Il sistema a molle bilancia il peso, rendendo la rampa leggera e sicura da maneggiare in autonomia.

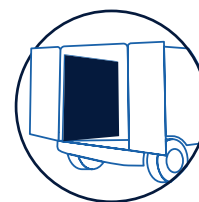
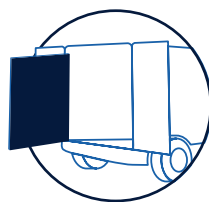
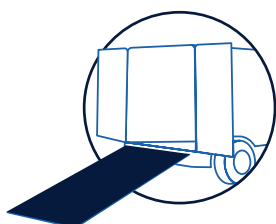
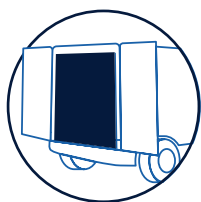

WM LIGHT PLUS

ESEMPI DI POSSIBILI CONFIGURAZIONI

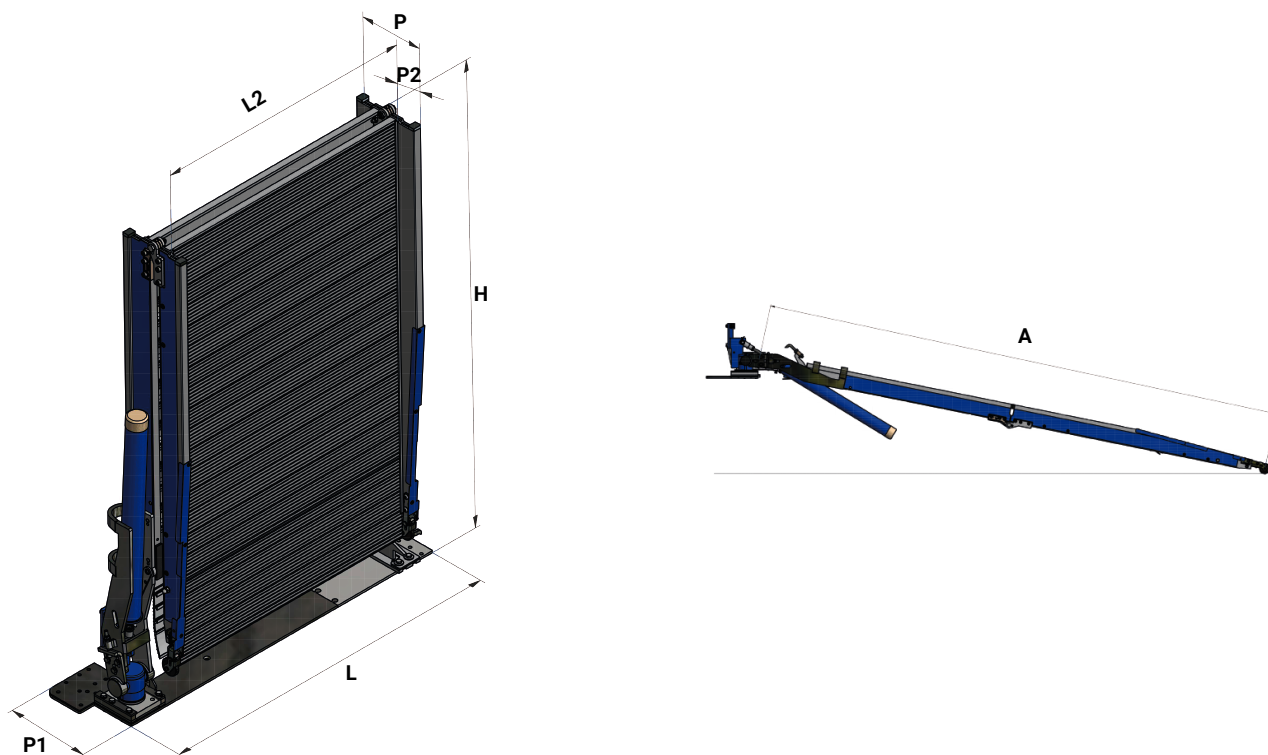

L2 (mm)	A (mm)	L (mm)	H (mm)	P (mm)	P1 (mm)	P2 (mm)	Capac. (Kg)	Peso* (Kg)
800	2200	1065	1175	203	250	60	600	71
900	2500	1165	1300	203	250	60	600	78
900	3000	1165	1425	203	250	60	600	83
950	3250	1215	1175	203	250	60	600	76
950	2700	1215	1550	203	250	60	600	89
1000	3000	1265	1425	203	250	60	400	87
1000	2500	1265	1675	203	250	60	400	96
1000	2700	1265	1800	203	250	60	400	101
1050	3250	1315	1425	203	250	60	400	89
1050	2800	1315	1675	203	250	60	400	98
1100	3000	1365	1550	203	250	60	400	96
1100	3000	1365	1800	203	250	60	400	106
1200	3250	1465	1425	203	250	60	400	95
1200	3200	1465	1675	203	250	60	400	105
1200	3250	1465	1800	203	250	60	400	111

* Il peso non comprende il kit di montaggio, che dipende dal furgone. (min. 2 Kg - max. 7 Kg)

WM LIGHT PLUS

OPTIONAL



ROTAZIONE INTERNA

Gancio utilizzabile per bloccare la rampa in posizione completamente ruotata all'interno del veicolo.



KIT SUPPLEMENTARE - 3° PEZZO

Riduce l'angolo di inclinazione per rampe pieghevoli in 3 pezzi, ideale per veicoli piccoli. Disponibile per portate fino a 600 kg.

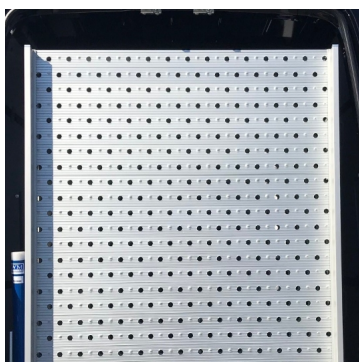

PIANO FORATO

È possibile avere la rampa con superficie in alluminio forato. Il piano risulta maggiormente antiscivolo e la portata rimane 600 kg.



USO A PONTE

Bandelle di forma ricurva e perno di bloccaggio cerniere, indicati per utilizzare la rampa come un ponte per connettere due superfici poste a diverse altezze.

WM LIGHT PLUS



WM LIGHT

DESCRIZIONE:

Rampa di carico removibile. È il modello più versatile della gamma WM e si adatta molto bene a carichi leggeri, fino ai 400 kg.



CARATTERISTICHE



Portata:
400kg



Movimentazione:
Removibile



Dimensioni personalizzate:
Larg. da 40 a 105 cm,
Lung. da 150 a 325 cm

- Piano in alluminio anodizzato antiscivolo
- Ruote per apertura facilitata
- Sgancio e aggancio rapido
- Bandella mobile di raccordo al piano

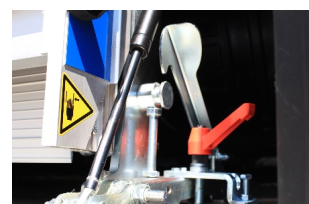

APERTURA E CHIUSURA:

Su richiesta è disponibile un kit di rotazione esterna che permette di aprire la rampa a bandiera di 90°, come una seconda porta.

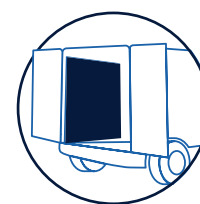
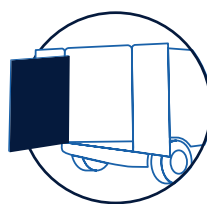
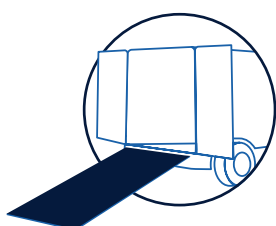
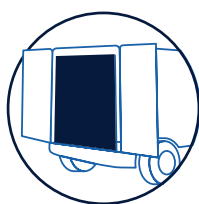

WM LIGHT

ESEMPI DI POSSIBILI CONFIGURAZIONI

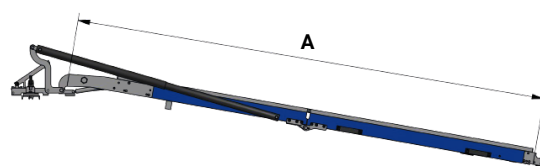
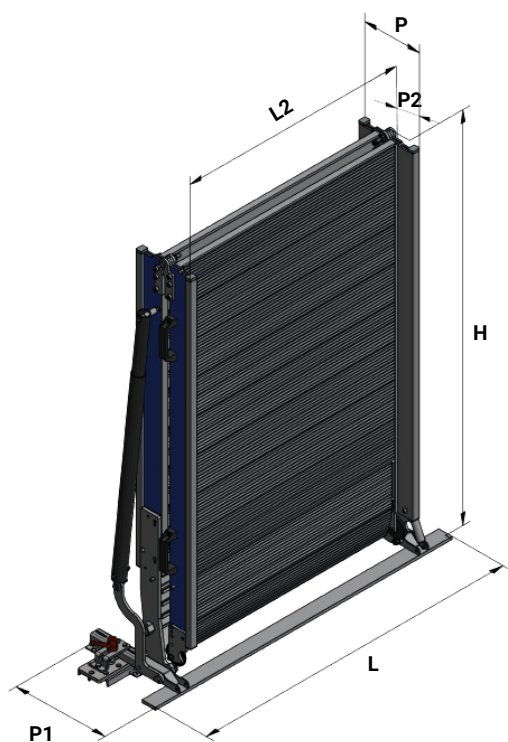

L2 (mm)	A (mm)	L (mm)	H (mm)	P (mm)	P1 (mm)	P2 (mm)	Capac. (Kg)	Peso* (Kg)
600	2000	900	1090	203	345	60	400	46
650	2250	950	1215	203	345	60	400	51
700	2000	1000	1090	203	345	60	400	49
750	2500	1050	1340	203	345	60	400	58
800	2750	1100	1465	203	345	60	400	64
800	3000	1100	1590	203	345	60	400	68
800	3250	1100	1715	203	345	60	400	72
850	2500	1150	1340	203	345	60	400	62
850	3250	1150	1715	203	345	60	400	75
900	3000	1200	1590	203	345	60	400	73
950	2750	1250	1465	203	345	60	400	71
1000	2500	1300	1340	203	345	60	400	68
1000	2750	1300	1465	203	345	60	400	73
1000	3000	1300	1590	203	345	60	400	78
1050	3250	1350	1715	203	345	60	400	85

)Il peso indicato non comprende il kit di montaggio 5 Kg. L'optional della rotazione esterna pesa + 6 kg

WM LIGHT

OPTIONAL



ROTAZIONE ESTERNA

Kit di rotazione che permette di ruotare la rampa verso l'esterno del furgone di 90°. consentendo l'accesso al piano del veicolo senza utilizzare la pedana.



USO A PONTE

Bandelle di forma ricurva e perno di bloccaggio cerniere, indicati per utilizzare la rampa come un ponte per connettere due superfici poste a diverse altezze.

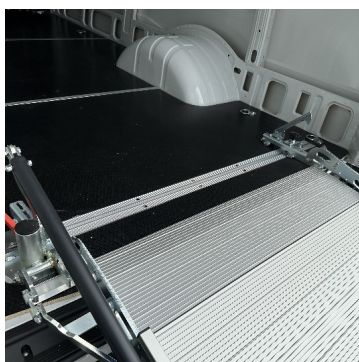

3 TIPI DI MONTAGGIO

- Montaggio Fixed
- Montaggio a 2 piastre
- Montaggio con barra completa



PIANO FORATO

È possibile avere la rampa con superficie in alluminio forato. Il piano risulta maggiormente antiscivolo e la portata rimane 400 kg.

WM LIGHT



WM LIGHT-R

DESCRIZIONE:

Rampa di carico adatta per trasporto persone. Ha il piano in alluminio retato per una buona visibilità sul retro.



CARATTERISTICHE



Portata:
300 kg



Movimentazione:
Removibile



Dimensioni personalizzate:
Larg. 80 e 100 cm,
Lung. da 150 a 325 cm

- Piano in alluminio retato
- Ruote per apertura facilitata
- Bordo laterale anti caduta (6 cm)
- Bandella mobile di raccordo al piano



APERTURA E CHIUSURA:

Su richiesta è disponibile un kit di rotazione esterna che permette di aprire la rampa a bandiera di 90°, come una seconda porta. La rampa può essere facilmente rimossa dal mezzo, tramite le maniglie poste sui lati della rampa.

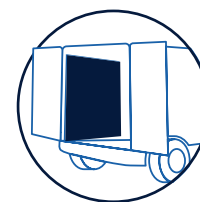
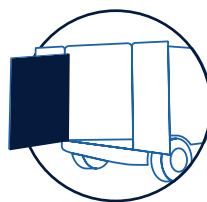
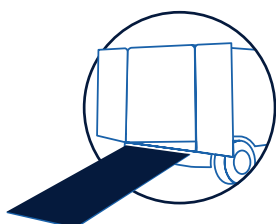
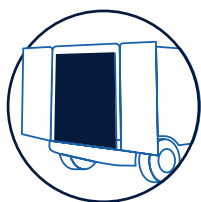

WM LIGHT-R

OPTIONAL



ROTAZIONE ESTERNA

Kit di rotazione che permette di ruotare la rampa verso l'esterno del furgone di 90°. consentendo l'accesso al piano del veicolo senza utilizzare la pedana (es. carico di pallet a mezzo carrelli elevatori sul furgone).

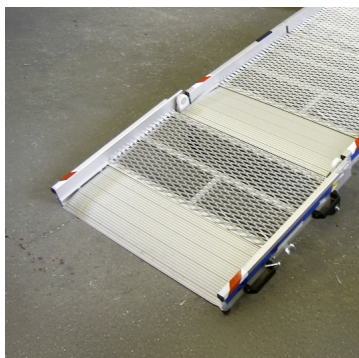

KIT SUPPLEMENTARE TERZO PEZZO

Riduce l'angolo di inclinazione della rampa, che è pieghevole in 3 parti. Ideale per veicoli di piccole dimensioni. Disponibile per carichi fino a 300 kg.

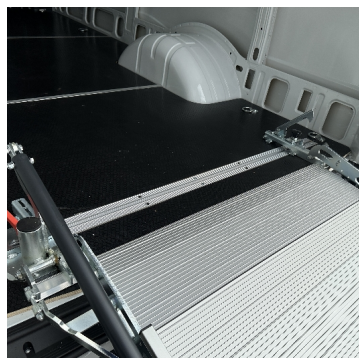

3 TIPI DI MONTAGGIO

- Montaggio Fixed
- Montaggio a 2 piastre
- Montaggio con barra completa



USO A PONTE

Bandelle di forma ricurva e perno di bloccaggio cerniere, indicati per utilizzare la rampa come un ponte per connettere due superfici poste a diverse altezze.

WM LIGHT-R



WM EASY

DESCRIZIONE:

Rampa di carico con posizionamento laterale, agile e semplice da utilizzare. Lascia il vano di carico sempre sgombro.



CARATTERISTICHE



Portata:
300 kg



Movimentazione:
Posizionamento laterale



Dimensioni personalizzate:
Larg. 80 cm,
Lung. 200, 225, 250, 275 e 300 cm

- Piano in alluminio anodizzato e forato
- Posizionamento laterale per il minimo ingombro
- Bordi laterali anti caduta
- Bandella mobile di raccordo al piano

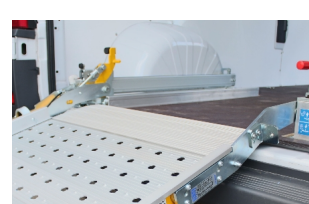

APERTURA E CHIUSURA:

La movimentazione con posizionamento laterale, agile e semplice da utilizzare, permette di lasciare il vano di carico sempre libero e riduce al minimo l'ingombro.

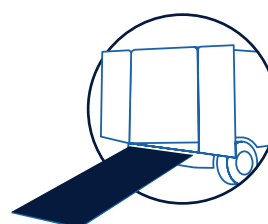
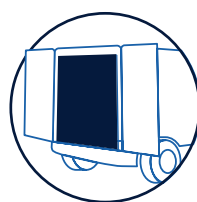
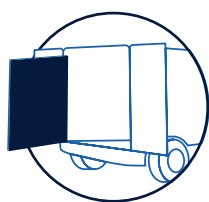
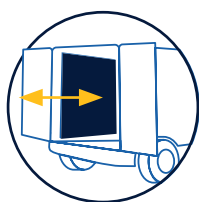

WM EASY

ESEMPI DI POSSIBILI CONFIGURAZIONI

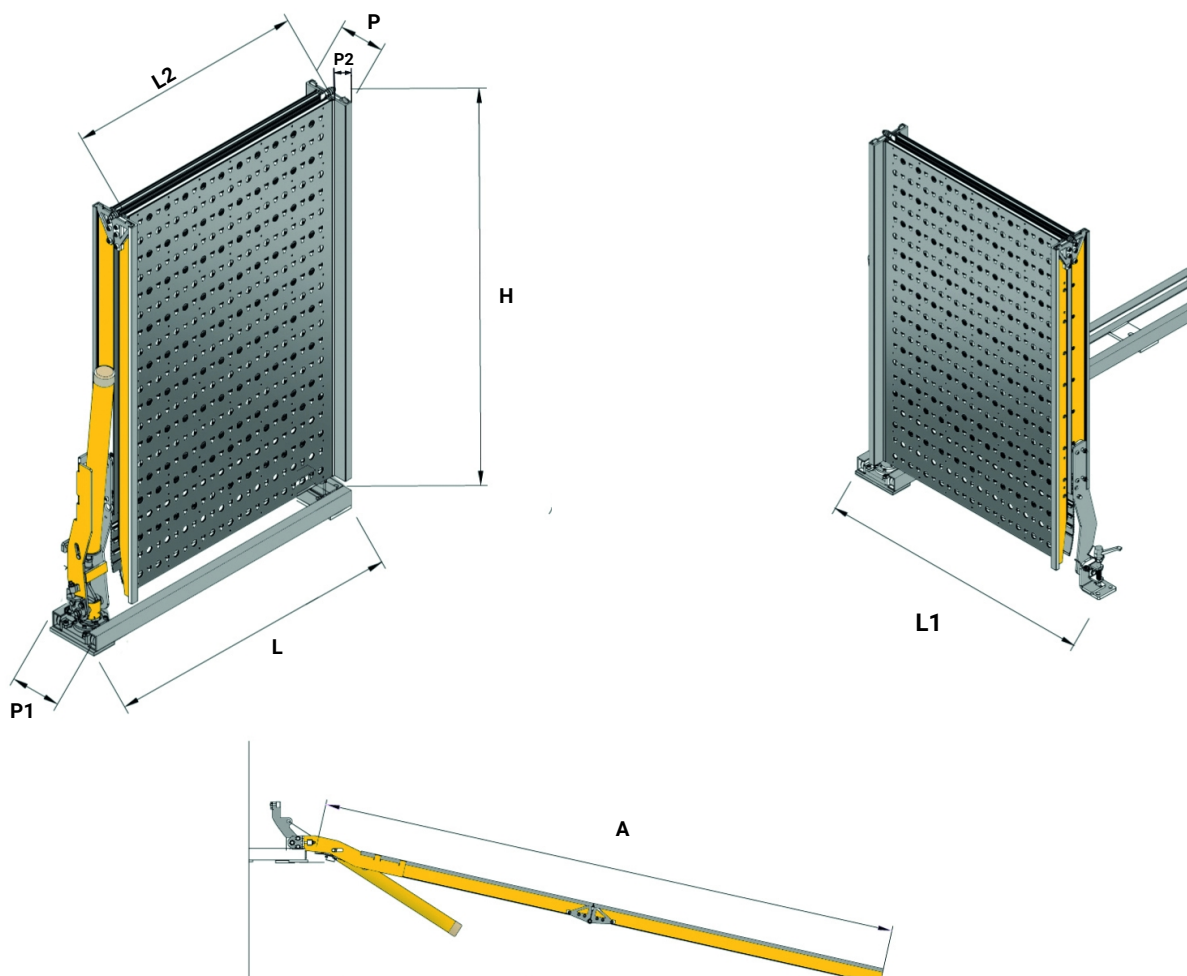

L2 (mm)	L (mm)	L1 (mm)	A (mm)	H (mm)	P (mm)	P1 (mm)	P2 (mm)	Capac. (Kg)	Peso (Kg)
800	1170	1180	2000	1180	155	250	45	300	64
800	1170	1180	2250	1305	155	250	45	300	67
800	1170	1180	2500	1430	155	250	45	300	70
800	1170	1180	2750	1555	155	250	45	300	73
800	1170	1180	3000	1680	155	250	45	300	75

WM EASY

OPTIONAL



VERSIONE DESTRA

Su richiesta è possibile fissare la rampa sul lato destro del furgone.

VANTAGGIO



VANO DI CARICO LIBERO:

Il posizionamento laterale garantisce l'accesso al piano, eliminando ogni ostacolo sul piano.

WM EASY

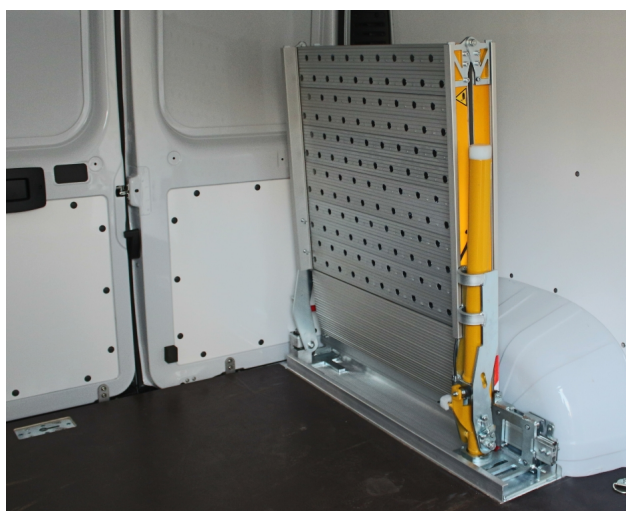

WM READY

DESCRIZIONE:

Un modello basico e indispensabile caratterizzato da un prezzo equo e un montaggio rapido.



CARATTERISTICHE



Portata:
300 kg



Movimentazione:
Removibile



Dimensioni personalizzate:
Larg. 80 cm,
Lung. 200, 225, 250 e 300 cm

- Piano in alluminio antiscivolo
- Bordi laterali anti caduta (4,5 cm)
- Doppia molla a gas per facilitare la movimentazione
- Sgancio e aggancio rapido



APERTURA E CHIUSURA:

La rampa può essere facilmente rimossa dal mezzo, tramite le maniglie poste sui lati della rampa. Una volta rimossa, il piano di carico rimane completamente libero. Questo sistema permette anche il trasferimento della rampa da un mezzo all'altro.

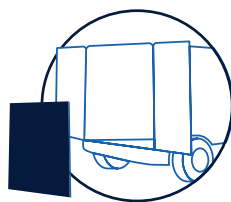
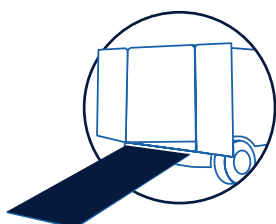
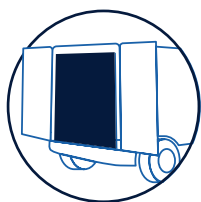

WM READY

ESEMPI DI POSSIBILI CONFIGURAZIONI

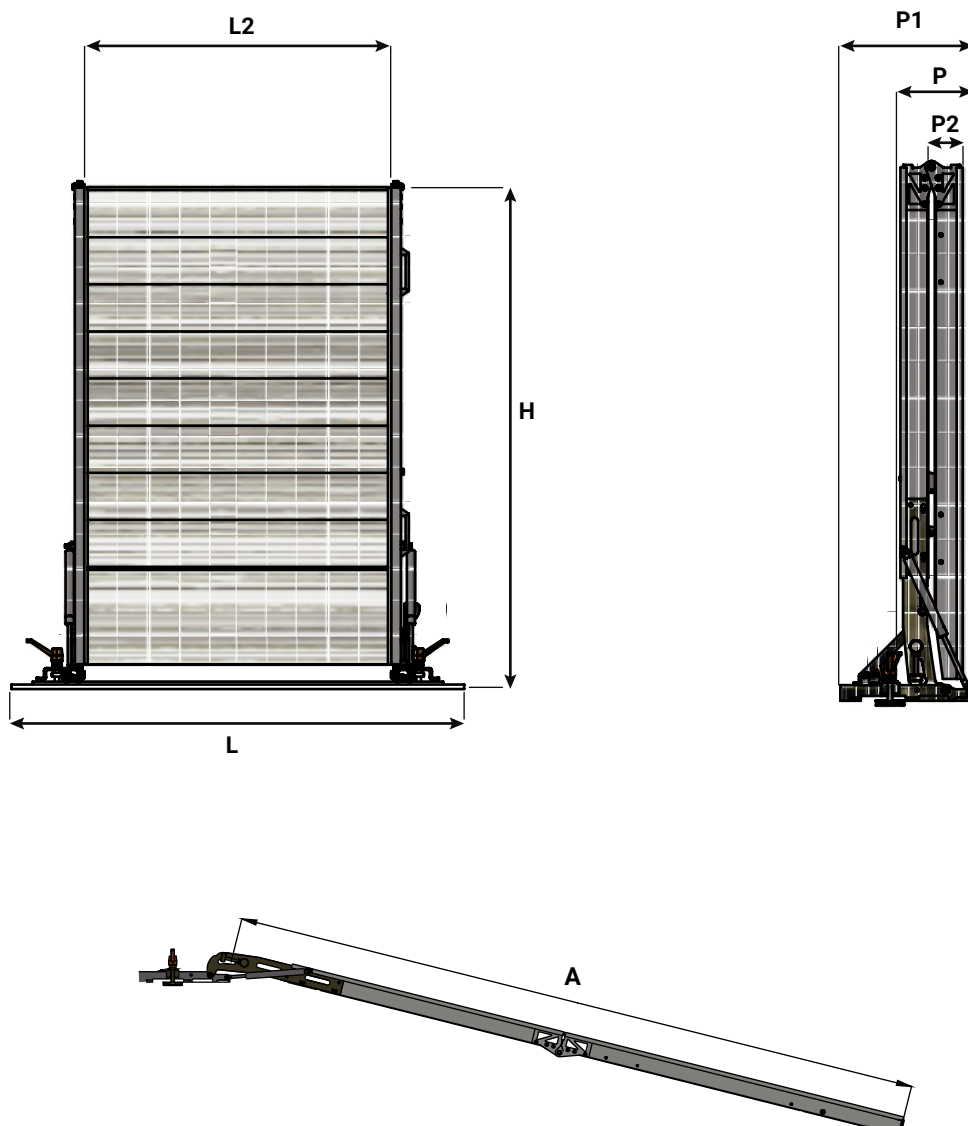

L2 (mm)	L (mm)	A (mm)	H (mm)	P (mm)	P1 (mm)	P2 (mm)	Capac. (Kg)	Peso* (Kg)
800	1090	2250	1215	185	330	45	300	33
800	1090	2500	1340	185	330	45	300	39
800	1090	3000	1590	185	330	45	300	45

* Il peso indicato non comprende il kit di montaggio che è di, 2 kg.

WM READY

OPTIONAL

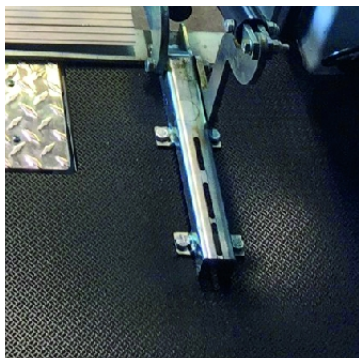

MONTAGGIO FISSO

Su richiesta è possibile montare una base fissa sulla rampa. Così facendo la rampa risulta fissa e non più removibile dal mezzo. Tale soluzione semplifica e velocizza le operazioni di montaggio, stimate di 30 minuti.

VANTAGGIO



GANCIO DI BLOCCAGGIO:

Garantisce sicurezza e semplicità d'uso.

WM READY



WM MOBILE

DESCRIZIONE:

Rampa di carico mobile. Si ripiega in 2 parti per essere facilmente riposta nel furgone, lavora in appoggio senza alcun montaggio.



CARATTERISTICHE



Portata:

300 kg a coppia



Movimentazione:

Mobile



Dimensioni personalizzate:

Larg. da 30 a 100 cm,

Lung. da 150 a 325 cm

- Piano in alluminio antiscivolo
- Bandella di appoggio al piano regolabile
- Bordi laterali anti caduta (5 cm)
- Quattro ruote e due maniglie per facilitare il trasporto

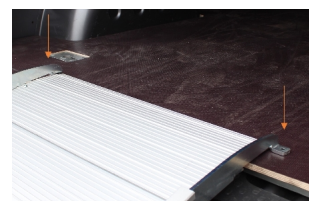

APERTURA E CHIUSURA:

Rampa mobile senza montaggio, lavora in appoggio. Lo speciale sistema d'appoggio è regolabile e prevede 4 posizioni per adattarsi al meglio alle varie altezze dei furgoni.

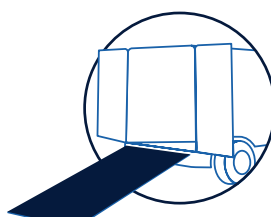
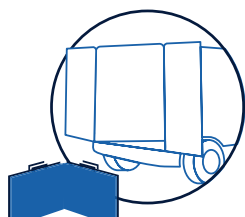
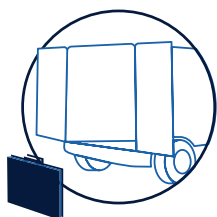

WM MOBILE

ESEMPI DI POSSIBILI CONFIGURAZIONI

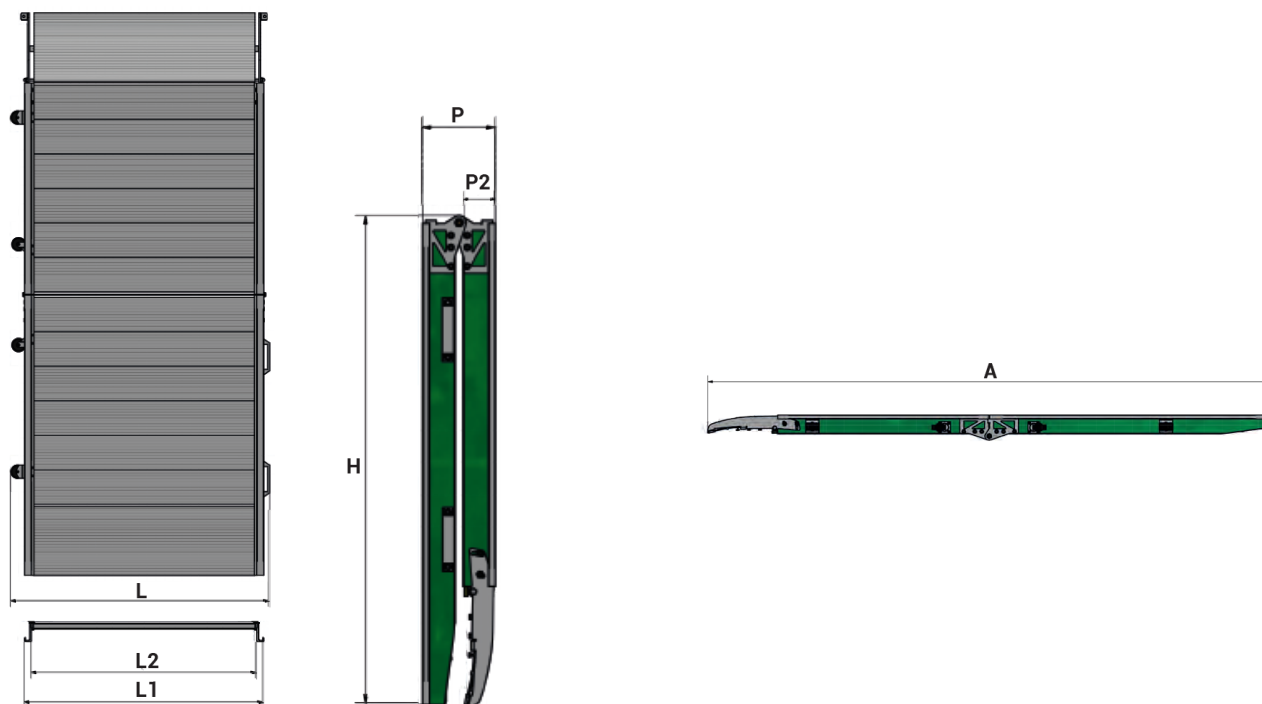

L2 (mm)	A (mm)	L1 (mm)	L (mm)	H (mm)	P (mm)	P2 (mm)	Capac. (Kg)	Peso* (Kg)
400	1750	465	905	155	155	45	300	20,5
500	2250	565	1155	155	155	45	300	28,5
600	2500	665	1280	95	155	45	300	34,5
650	2750	736	1405	95	155	45	300	39,5
700	3000	786	1530	95	155	45	300	44,5
700	2000	836	1030	95	155	45	300	31,5
750	2500	836	1280	95	155	45	300	39,5
800	2000	886	1030	95	155	45	300	*27,5
800	2500	936	1280	95	155	45	300	*32,5
800	3000	936	1530	95	155	45	300	*38,5
800	3250	936	1655	95	155	45	300	52,5
850	2000	986	1030	95	155	45	300	36,5
900	3000	1036	1530	95	155	45	300	53,5
1000	2500	1136	1280	95	155	45	300	48,5
1000	3000	1136	1530	95	155	45	300	57,5

* versione alleggerita

WM MOBILE

OPTIONAL

PIANO ANODIZZATO

Per una maggior resistenza nel tempo e un aspetto estetico più gradevole è possibile effettuare il trattamento di anodizzazione dell'alluminio.



MOBILE PEZZO UNICO

Su richiesta si può produrre la rampa con le cerniere bloccate rendendola un pezzo unico.

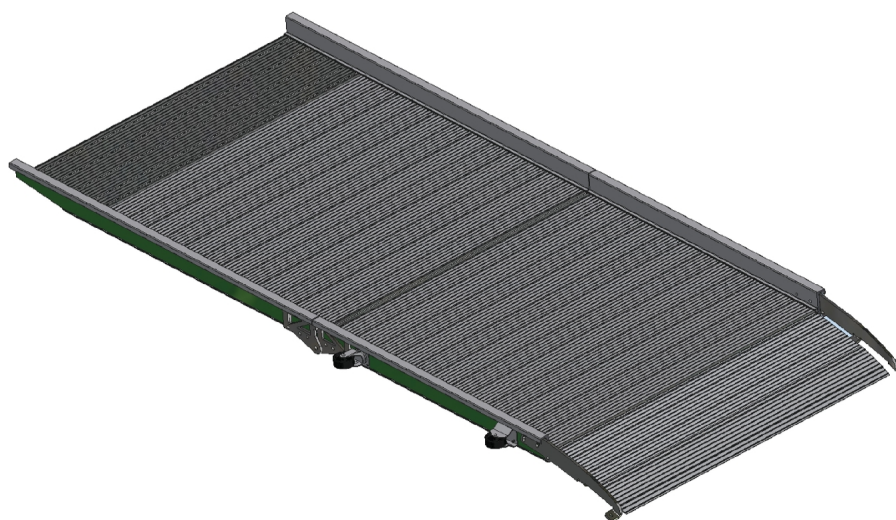

WM MOBILE



WM TELESCOPIC

DESCRIZIONE:

Rampa telescopica mobile, pratica e semplice da usare. In alluminio di colore giallo catarifrangente antiscivolo forato e bordi anticaduta.



CARATTERISTICHE



Portata:

300 kg a coppia



Movimentazione:

Mobile



Dimensioni personalizzate:

Larg. 18,5 cm,

Lung. 150, 200, 225, 250 e 300 cm

- Piano in alluminio anodizzato e forato
- Maniglia per il trasporto
- Bordi laterali anticaduta (5,5cm)
- Bandella di appoggio al piano regolabile e con smusso
- La rampa di carico WM Telescopic può essere venduta singolarmente o a coppia in base alle esigenze.



APERTURA E CHIUSURA:

La rampa è telescopica e lavora in appoggio. È dotato di uno speciale sistema d'appoggio tramite bandella ripieghevole, progettato per garantire una connessione sicura al veicolo, sebbene la rampa non sia ancorata al mezzo. Le due parti sono sfilabili e vengono fatte scorrere una nell'altra.

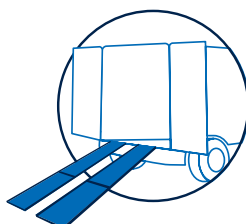
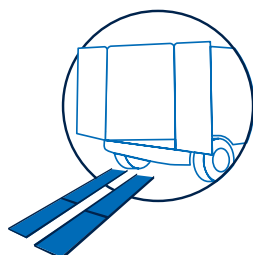
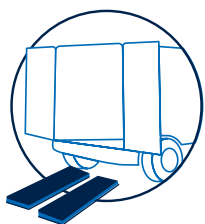

WM TELESCOPIC

ESEMPI DI POSSIBILI CONFIGURAZIONI

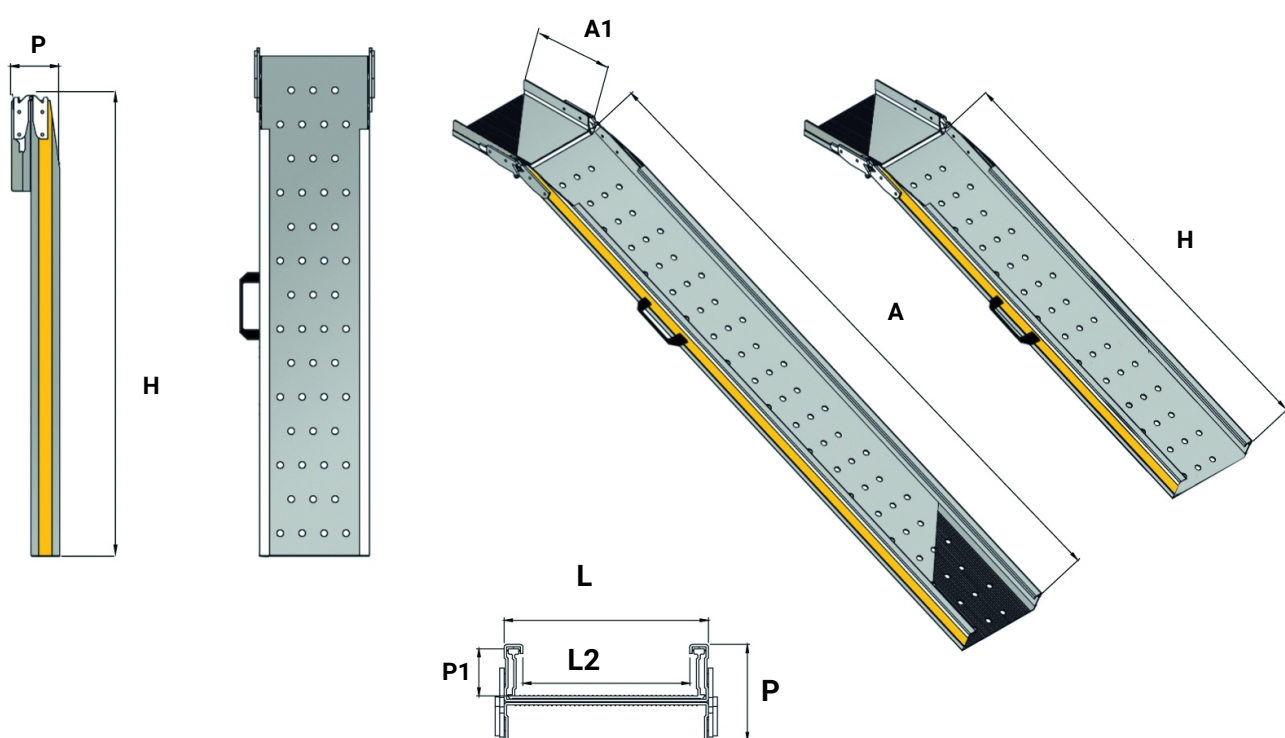

L2 (mm)	A1 (mm)	L (mm)	A (mm)	H (mm)	P (mm)	P1 (mm)	Capac. A coppia (Kg)	Peso* (Kg)
185	200	225	1500	900	106	55	300	5
185	200	225	2000	1150	106	55	300	6
185	200	225	2250	1275	106	55	300	6,5
185	200	225	2500	1400	106	55	300	7
185	200	225	3000	1650	106	55	300	8

* Il peso non comprende il kit di montaggio, che dipende dal furgone. (min. 2 Kg - max. 7 Kg)

WM TELESCOPIC

OPTIONAL

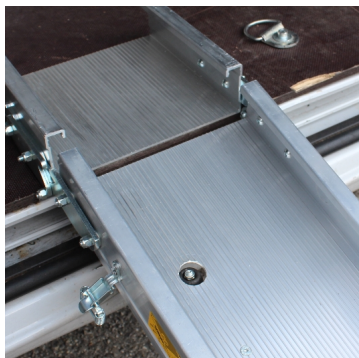

VERSIONE ECO

È disponibile la versione ECO: piano di carico senza fori, senza smusso nella bandella e senza colorazione gialla sui bordi laterali.

VANTAGGIO

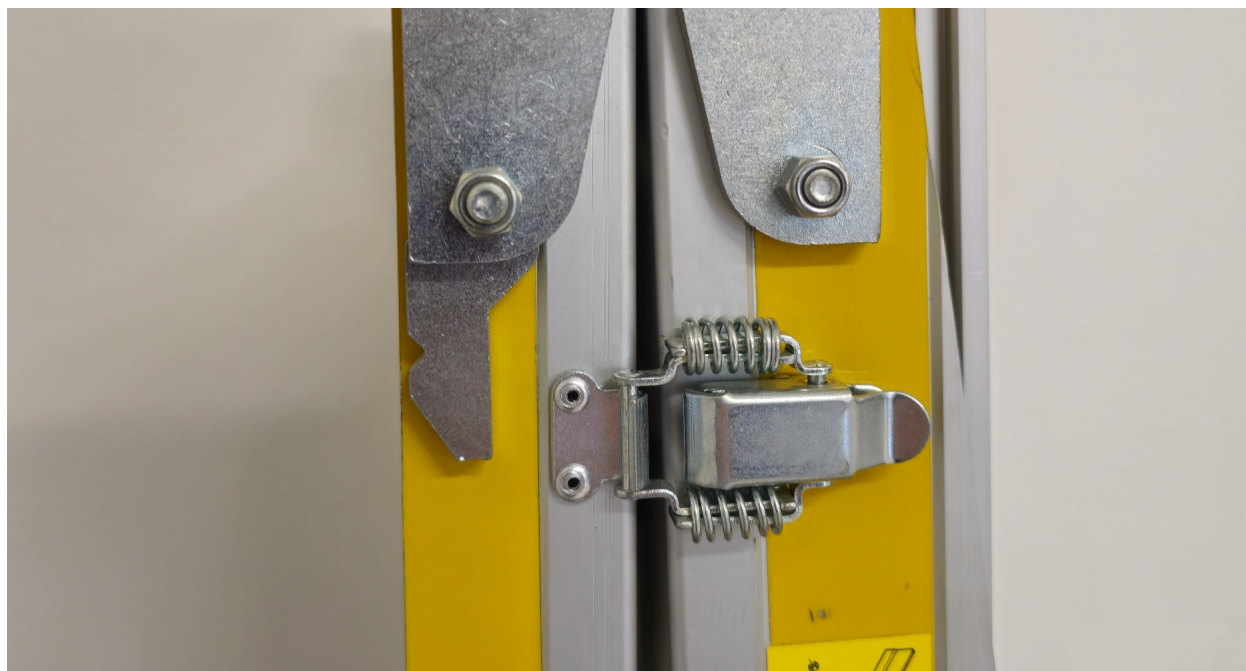

GANCIO DI BLOCCAGGIO:

Garantisce sicurezza e semplicità d'uso.

WM TELESCOPIC

