



[www.wmsystem.com](http://www.wmsystem.com)

PROFESSIONAL | LIGHT | FAST



# LOADING RAMPS

WE SOLVE ALL YOUR LOADING AND UNLOADING NEEDS,  
WITH RAMPS MADE TO MEASURE FOR EVERY TYPE OF VEHICLE.

# WM SYSTEM

## A HISTORY OF INNOVATION

Since the time of its incorporation, WM System has been delivering adaptable solutions designed to meet people's needs. The development of each WM System product is guided by principles of simplicity, safety and quality along with a commitment to suit the needs of the end user.

The company has grown in line with these strategies, separating its operations into separate divisions, all of which share the objective of lightening the load.

Expanding on our expertise in commercial loading ramps, we have continued to develop products to meet the needs of our customers. With recent expansion into the access ramps sector, we are able to cater for all loading needs

while maximising accessibility and promoting personal independence.

The latest model in our product range is called WM Flexy. The modular cart, which can be built up as required to facilitate and organise work.

All our products are manufactured in Italy using top quality materials. Genuine Italian design and production are just two of the reasons why our customers place their trust in our company and choose our products time after time.

Owing to our passion and commitment to continuous research, we are the European leader in the loading ramps sector. Every year, new customers choose WM System as a reliable partner to help them in their business development process.

### LOADING RAMPS

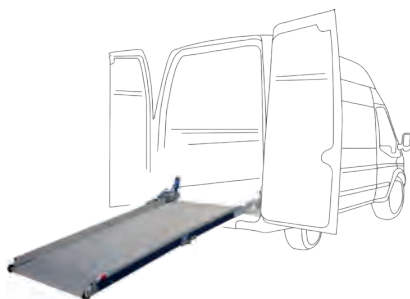

### ACCESS RAMPS

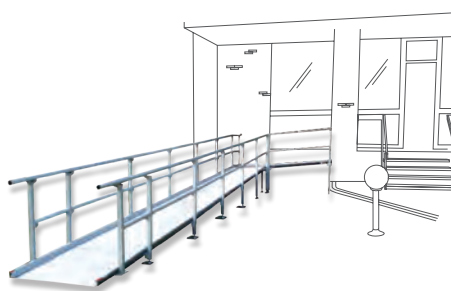

### CART



## A COMPREHENSIVE SERVICE



BESPOKE TECHNICAL  
ADVICE



TAILOR-MADE  
DESIGN



100% ITALIAN  
PRODUCTION



FAST DELIVERY  
TIMES



AFTER-SALES  
SERVICE

## ALL WM SYSTEM RAMPS HAVE



TÜV QUALITY  
CONFIRMATION



TYPE APPROVAL  
NOT NEEDED



2 YEAR  
WARRANTY



PATENTED  
SYSTEM



ITALIAN  
ENGINEERING

## WHY CHOOSE OUR RAMPS?

### FLEXIBILITY

Full range of manual ramps suitable for all sectors and all specific needs

### QUALITY

With our in-house welding and CNC departments, we can guarantee unbeatable quality standards. Our ramps are rugged and durable

### TIME SAVING

Reduced loading and unloading times, with only a single operator needed

### SAFETY

Managed risks with safer and better working environment

THANKS TO OUR WORLDWIDE NETWORK OF DISTRIBUTORS, WE CAN PROVIDE EVERY CUSTOMER WITH CUSTOMISED SUPPORT AND ASSISTANCE

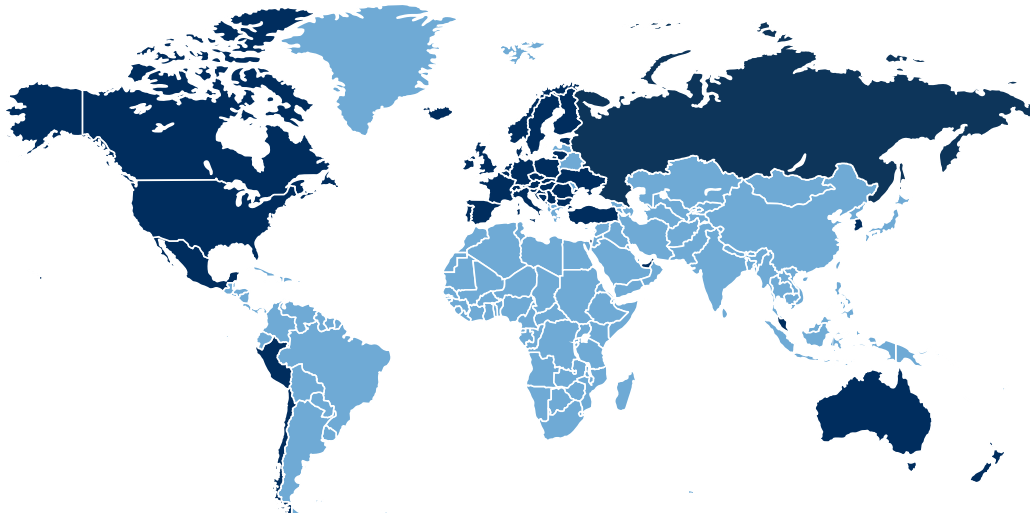

COUNTRIES IN WHICH  
WE ARE PRESENT

# WM PC

LOADING RAMP  
WITH CAPACITY  
OF UP TO 1800  
KG, SUITABLE FOR  
LIGHT COMMERCIAL  
VEHICLES. MORE THAN  
500 SIZES AVAILABLE



**LOAD CAPACITY**  
600 / 1000 / 1500 /  
1800 kg



**CUSTOMISED  
DIMENSIONS**  
Width from  
60 to 137.5 cm  
Length from  
195 to 325 cm



**HANDLING**  
External and internal  
swivelling



**COLOUR**  
Red

LOAD CAPACITY: UP TO 1800 KG

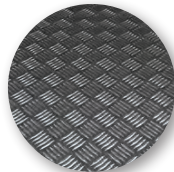

Shot-blasted non-slip  
aluminium surface



Wheel for assisted  
deployment



Self-positioning  
adjustable feet



Mobile contact flap to  
connect to the floor of the van





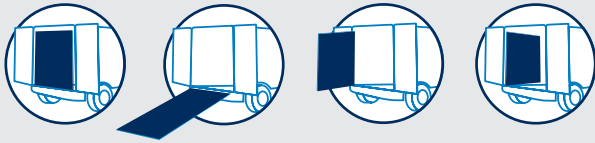

## DEPLOYMENT AND CLOSING

The PC is the most complete and practical of WM System's loading ramps. Suitable for most loading and weight requirements, it is extremely practical thanks to the patented horizontal swivel opening. The spring system balances the weight of the ramp during use, allowing it to be handled safely and easily by a single operator.

## OPTIONAL EXTRAS



### INTERNAL LATCH

Latch to secure the ramp in its fully swivelled position inside the vehicle.

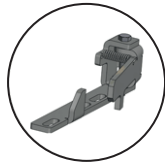

### WIND SAFETY KIT

Allows the ramp to be secured when swivelled fully outward. This feature ensures that gusts of wind cannot cause the ramp to rotate, with the risk of striking persons or objects.



### SUPPLEMENTARY 3RD PIECE KIT

Reduces the ramp angle and results in three folding ramp sections. Ideal for use with small vehicles. Available with capacities up to 1,000 kg, max. width of 100 cm and fixed length of 80 cm.



### REMOVABLE EXTENSION KIT

Third removable piece equipped with wheels, to be added to the ramp when necessary. Available for capacities up to 1500 kg.

## APPLICATION SECTORS



CLEANING EQUIPMENT



BUILDING CONSTRUCTION



LAUNDRY TROLLEYS



GARDENING LAWN TRACTORS QUAD BIKES



VENDING MACHINES VIDEO SLOT MACHINES



PALLETS

## EXAMPLES OF POSSIBLE CONFIGURATIONS MODEL WM PC

L2 (mm)	A (mm)	L (mm)	H (mm)	P (mm)	P1 (mm)	P2 (mm)	Capac. (Kg)	Weight* (Kg)
900	2200	1165	1215	95	250	8	600	81
950	2500	1215	1365	95	250	8	600	88
1000	3000	1265	1615	95	250	8	1000	106
1000	3250	1265	1740	95	250	8	1500	124
1050	2700	1315	1515	95	250	8	600	96
1100	3000	1365	1615	95	250	8	1500	131
1100	2500	1365	1365	95	250	8	1000	106
1200	2700	1465	1465	95	250	8	1000	117
1200	3250	1465	1740	95	250	8	1500	148
1250	2800	1515	1515	95	250	8	1000	128
1250	3000	1515	1615	95	250	8	1500	145
1300	3000	1565	1615	95	250	8	1000	139
1300	3250	1565	1740	95	250	8	1500	159
1350	3200	1615	1715	95	250	8	1500	160
1350	3250	1615	1740	95	250	8	1800	171

\* The specified weight does not include the installation kit, which depends on the van (min. 2 kg - max. 7 kg)

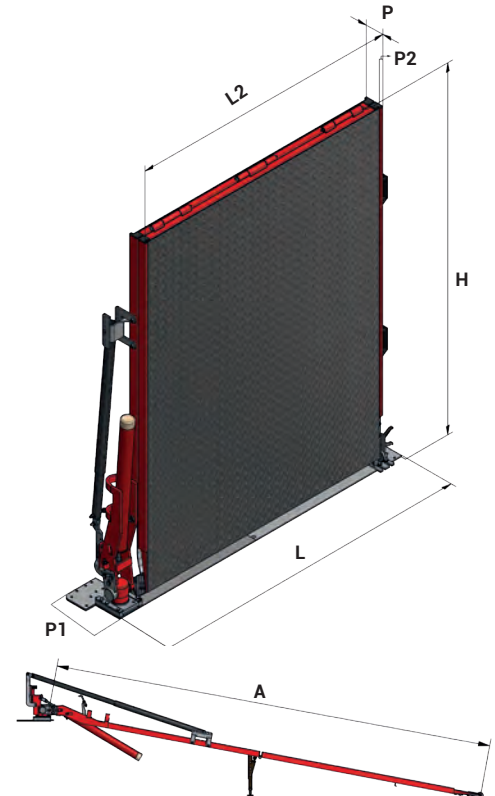

# WM ME

SIMPLE AND ROBUST  
LOADING RAMP.  
SUITABLE FOR HEAVY  
LOADS, CAPACITY FROM  
600 KG TO 1800 KG



**LOAD CAPACITY**  
600 / 1000 / 1500 /  
1800 kg

CUSTOM  
DIMENSIONS

**CUSTOMISED  
DIMENSIONS**  
Width from  
60 to 137.5 cm  
Length from  
195 to 325 cm



**HANDLING**  
Horizontal  
deployment



**COLOUR**  
Green

LOAD CAPACITY: UP TO 1800 KG



Anti-slip rice-pattern  
aluminium platform



Wheel for assisted  
deployment

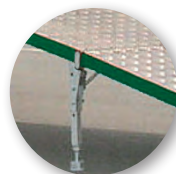

Self-positioning  
adjustable feet



Mobile contact flap to connect  
to the floor of the van



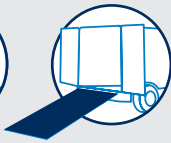

## DEPLOYMENT AND CLOSING

The ME ramp is popular for customers needing to load heavy equipment. Deployment of the ramp is simple and quick, thanks to its spring-assisted, fixed vertical, two-section opening. A double-spring version can be supplied on request for larger versions.

## OPTIONAL EXTRAS

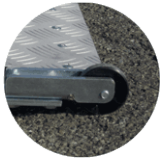

### LEFT HAND SIDE WHEEL KIT

Designed to facilitate ramp deployment, closing and handling. Right hand as standard, or available on left-hand side as an option.

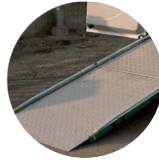

### FOLDING SAFETY EDGES

Aluminium safety edges to enhance safety in certain operating conditions.



### SUPPLEMENTARY 3RD PIECE KIT

Reduces the ramp angle and results in three folding ramp sections. Ideal for use with small vehicles. Available with capacities up to 1,000 kg, max. width of 100 cm and fixed length of 80 cm.



### REMOVABLE EXTENSION KIT

Third removable piece equipped with wheels, to be added to the ramp when necessary. Available for capacities up to 1500 kg, with maximum width of 100 cm.

## APPLICATION SECTORS



GARDENING  
LAWN  
TRACTORS



BUILDING  
CONSTRUCTION



QUAD BIKES



CLEANING  
MACHINES



PALLET  
TRUCKS



PALLETS

## EXAMPLES OF POSSIBLE CONFIGURATIONS MODEL WM ME

L2 (mm)	A (mm)	L (mm)	H (mm)	P (mm)	P1 (mm)	P2 (mm)	Capac. (Kg)	Weight* (Kg)
900	2200	1165	1215	95	250	8	600	79
950	2500	1215	1365	95	250	8	600	86
1000	3000	1265	1615	95	250	8	1000	104
1000	3250	1265	1740	95	250	8	1500	122
1050	2700	1315	1515	95	250	8	600	94
1100	3000	1365	1615	95	250	8	1500	129
1100	2500	1365	1365	95	250	8	1000	104
1200	2700	1465	1465	95	250	8	1000	115
1200	3250	1465	1740	95	250	8	1500	146
1250	2800	1515	1515	95	250	8	1000	126
1250	3000	1515	1615	95	250	8	1500	143
1300	3000	1565	1615	95	250	8	1000	137
1300	3250	1565	1740	95	250	8	1500	157
1350	3200	1615	1715	95	250	8	1500	158
1350	3250	1615	1740	95	250	8	1800	169

\* The specified weight does not include the installation kit, which depends on the van. (min. 2 kg - max. 7 kg)

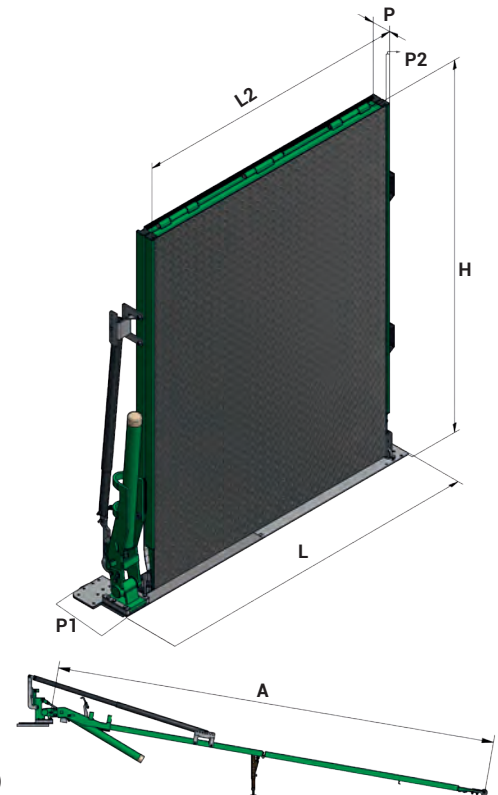



# WM PC-R WM ME-R

LOADING RAMP WITH  
ANTI-SLIP MESH  
PLATFORM, SUITABLE  
FOR LOADING  
EQUIPMENT WITH  
LARGE TYRED WHEELS



**LOAD CAPACITY**  
500 kg



**CUSTOMISED  
DIMENSIONS**  
Width from  
60 to 137.5 cm  
Length from  
195 to 325 cm



**HANDLING**  
**PC-R** internal-external  
swivelling  
**ME-R** horizontal  
deployment



**PC-R COLOUR**  
Blue



**ME-R COLOUR**  
Green

LOAD CAPACITY: UP TO 500 KG

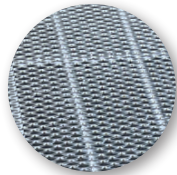

Anti-slip mesh platform

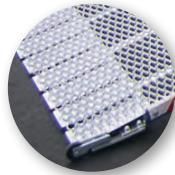

Wheel for assisted  
deployment

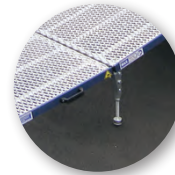

Self-positioning  
adjustable feet

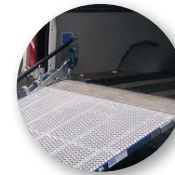

Mobile contact flap to  
connect to the floor of the van





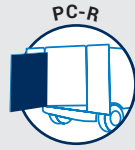
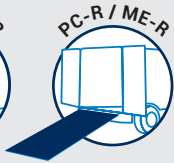

## DEPLOYMENT AND CLOSING

The PC-R and ME-R offer excellent grip for loading goods with large, tired wheels. The galvanised, expanded metal surface is extremely durable and allows for easy cleaning. Both have the patented, spring-assisted vertical opening for ease of use, with the horizontal swivel offered on the PC-R.

## OPTIONAL EXTRAS

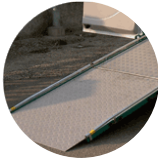

### FOLDING SAFETY EDGES

Aluminium safety edges to enhance safety in certain operating conditions.



### SPECIAL FEET

For loading machines with very low ground clearance, special feet can be supplied to create two different ramp slopes for easier ascent. The specified weight does not include the installation kit, which depends on the van. (min. 2kg - max. 7 kg)



### SUPPLEMENTARY 3RD PIECE KIT

Reduces the ramp angle and results in three folding ramp sections. Ideal for use with small vehicles. Available with capacities up to 1,000 kg, max. width of 100 cm and fixed length of 80 cm.

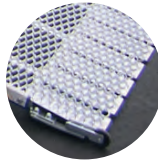

### LEFT HAND SIDE WHEEL KIT

Designed to assist the ramp deployment further on to hard ground.

## APPLICATION SECTORS



GARDENING  
LAWN  
TRACTORS



MOTORBIKES  
BICYCLES



QUAD BIKES

## EXAMPLES OF POSSIBLE CONFIGURATIONS MODEL WM PC-R AND WM ME-R

L2 (mm)	A (mm)	L (mm)	H (mm)	P (mm)	P1 (mm)	P2 (mm)	Capac. (Kg)	Weight* (Kg)
900	2200	1165	1215	95	250	8	500	80
950	2500	1215	1365	95	250	8	500	87
1000	3000	1265	1615	95	250	8	500	105
1000	3250	1265	1740	95	250	8	500	111
1050	2700	1315	1515	95	250	8	500	95
1100	3000	1365	1615	95	250	8	500	120
1100	2500	1365	1365	95	250	8	500	105
1200	2700	1465	1465	95	250	8	500	116
1200	3250	1465	1740	95	250	8	500	135
1250	2800	1515	1515	95	250	8	500	115
1250	3000	1515	1615	95	250	8	500	134
1300	3000	1565	1615	95	250	8	500	138
1300	3250	1565	1740	95	250	8	500	150
1350	3200	1615	1715	95	250	8	500	151
1350	3250	1615	1740	95	250	8	500	152

\* The specified weight does not include the installation kit, which depends on the van. (min. 2 kg - max. 7 kg)

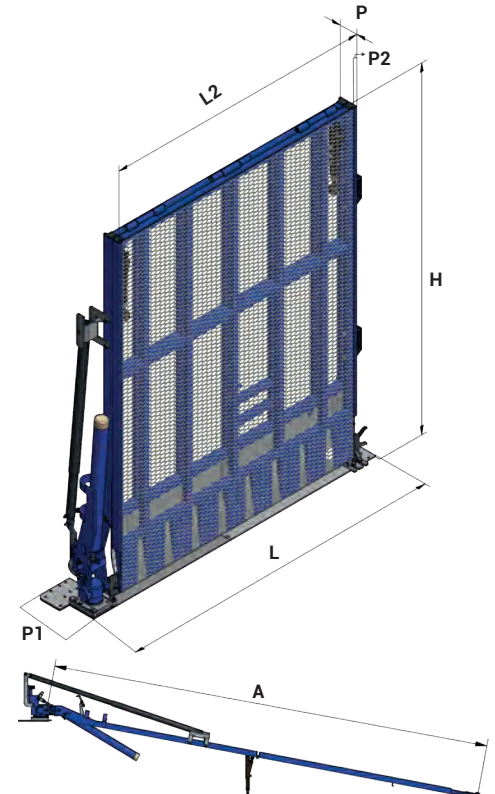

# WM LIGHT PLUS

STRONG, LIGHTWEIGHT ALUMINIUM LOADING RAMP FOR LOADS OF UP TO 600 KG. WITH EXTERNAL SWIVEL FUNCTION FOR RAPID ACCESS TO THE VAN'S CARGO AREA.



**LOAD CAPACITY**  
400 kg and 600 kg



**CUSTOMISED DIMENSIONS**  
Width from 40 to 120 cm  
Length from 175 to 325 cm



**HANDLING**  
External swivelling



**COLOUR**  
Blue

LOAD CAPACITY: UP TO 600 KG



Anti-slip anodised aluminium platform

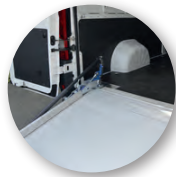

Flexible contact plate to the van floor



Two wheels for easy deployment

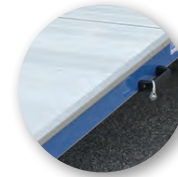

Safety edges (6 cm)



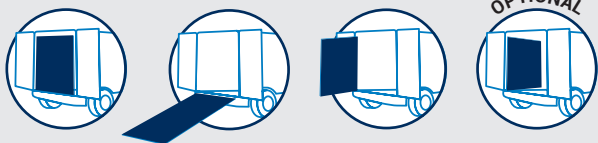

## DEPLOYMENT AND CLOSING

The WM Light Plus ramp is constructed from reinforced aluminium making it lightweight and very easy to use due to its patented spring-assisted system. The built-in swivel feature allows the ramp to pivot externally at 90 degrees giving the operator full access to the rear of the vehicle when required. The anti-slip surface provides a safe loading platform with raised lateral anti-fall edges increasing load safety. The ramp can swivel internally with an optional kit.

## OPTIONAL EXTRAS

### INTERNAL SWIVELLING



Swivel kit that makes it possible to rotate the ramp through 90° toward the interior of the van. Complete with a special latch, to which the ramp is secured inside the van.



### PERFORATED PLATFORM

WM System exclusive platform style. Platform surface in perforated aluminium with alternated convex holes. For maximum grip in the presence of water, rain and snow. Exceptionally light weight.

### FLEXIBLE PLATE FOR DOCK-LOADING



By using a supplied pin, the ramp can be locked open to allow dock, or vehicle to vehicle loading at various heights.



### SUPPLEMENTARY 3RD PIECE KIT

Reduces the ramp angle and results in 3 folding ramp sections. Ideal for use with small vehicles. Available for load capacities up to 600 kg. Max. width of 100 cm and fixed length of 80 cm.

## APPLICATION SECTORS



HEALTHCARE & MEDICAL



CATERING



EVENTS CONCERTS



GENERAL CLEANING EQUIPMENT



MOTORBIKES BICYCLES



LAUNDRY TROLLEYS

## EXAMPLES OF POSSIBLE CONFIGURATIONS MODEL WM LIGHT PLUS

L2 (mm)	A (mm)	L (mm)	H (mm)	P (mm)	P1 (mm)	P2 (mm)	Capac. (Kg)	Weight* (Kg)
800	2000	1065	1175	203	250	60	600	71
900	2250	1165	1300	203	250	60	600	78
900	2500	1165	1425	203	250	60	600	83
950	2000	1215	1175	203	250	60	600	76
950	2750	1215	1550	203	250	60	600	89
1000	2500	1265	1425	203	250	60	400	87
1000	3000	1265	1675	203	250	60	400	96
1000	3250	1265	1800	203	250	60	400	101
1050	2500	1315	1425	203	250	60	400	89
1050	3000	1315	1675	203	250	60	400	98
1100	2750	1365	1550	203	250	60	400	96
1100	3250	1365	1800	203	250	60	400	106
1200	2500	1465	1425	203	250	60	400	95
1200	3000	1465	1675	203	250	60	400	105
1200	3250	1465	1800	203	250	60	400	111

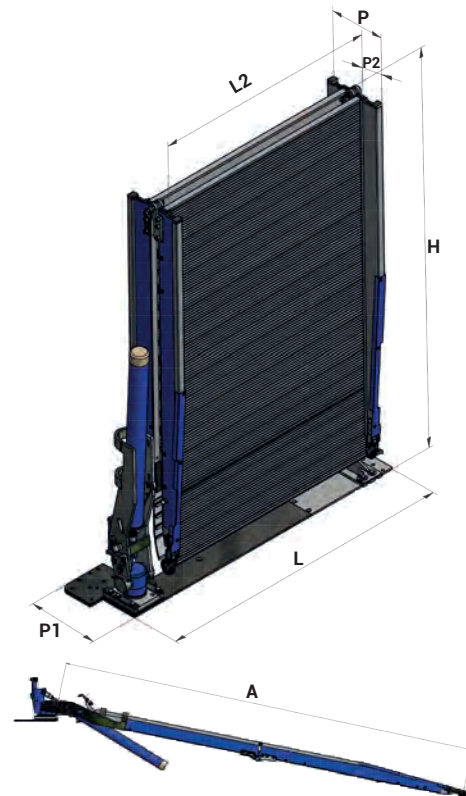

\* The specified weight does not include the installation kit, which depends on the van. (min. 2 kg - max. 7 kg)



# WM LIGHT

DETACHABLE LOADING RAMP. THIS IS THE MOST VERSATILE MODEL IN THE WM RANGE, ESPECIALLY SUITABLE FOR LIGHT LOADS OF UP TO 400 KG.



**LOAD CAPACITY**  
400 kg



**CUSTOMISED DIMENSIONS**  
Width from 40 to 105 cm  
Length from 150 to 325 cm



**HANDLING**  
Removable



**COLOUR**  
Blue

LOAD CAPACITY: UP TO 400 KG



Anti-slip anodised aluminium platform

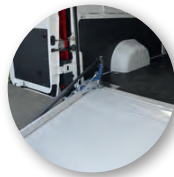

Flexible contact plate to the van floor



Two wheels for easy deployment



Quick release and coupling



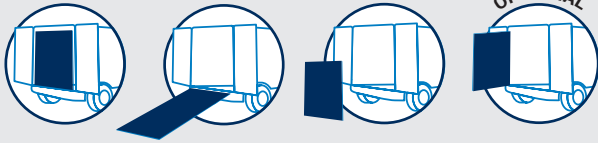

**DEPLOYMENT:** The WM Light is extremely lightweight, using both spring and gas strut assistance. An external swivel kit is supplied on request, making it possible to gain access to the van like a second door.

**DETACHABLE AND VERSATILE:** Quick release handles allow for easy removal of the ramp, leaving the load area unobstructed. The keyhole locating plates allow for easy and quick transfer between vehicles.

### OPTIONAL EXTRAS



#### EXTERNAL SWIVELLING

Swivel kit that makes it possible to rotate the ramp through 90° toward the exterior of the van. Allows access to the van's cargo area without using the ramp.

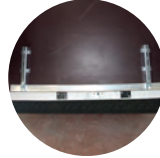

#### 3 TYPES OF ASSEMBLY

- Fixed-version mounting
- Two-plate mounting
- Mounting with bar



#### GANGWAY CONFIGURATION

Thanks to a special pin that locks the hinge, the ramp can be used in gangway mode to connect two surfaces at different heights (vehicles and steps, loading docks, etc...)

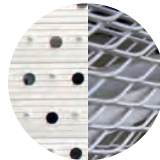

#### PLATFORM VERSIONS

The ramp is available with a platform surface in perforated aluminium with alternated convex holes, WM LIGHT-F model. This improves the platform's anti-slip properties while retaining the 400 kg load capacity. An aluminium extended mesh version, known as WM LIGHT-R, is available as an alternative. Max. load capacity: 300 kg.

### APPLICATION SECTORS



CLEANING EQUIPMENT



CATERING



MOTORBIKES BICYCLES



ELECTRICIANS PLUMBING AND HEATING ENGINEERS



MEDICAL AMBULANCES



EVENTS CONCERTS

### EXAMPLES OF POSSIBLE CONFIGURATIONS MODEL WM LIGHT PLUS

L2 (mm)	A (mm)	L (mm)	H (mm)	P (mm)	P1 (mm)	P2 (mm)	Capac. (Kg)	Weight* (Kg)
600	2000	900	1090	203	345	60	400	46
650	2250	950	1215	203	345	60	400	51
700	2000	1000	1090	203	345	60	400	49
750	2500	1050	1340	203	345	60	400	58
800	2750	1100	1465	203	345	60	400	64
800	3000	1100	1590	203	345	60	400	68
800	3250	1100	1715	203	345	60	400	72
850	2500	1150	1340	203	345	60	400	62
850	3250	1150	1715	203	345	60	400	75
900	3000	1200	1590	203	345	60	400	73
950	2750	1250	1465	203	345	60	400	71
1000	2500	1300	1340	203	345	60	400	68
1000	2750	1300	1465	203	345	60	400	73
1000	3000	1300	1590	203	345	60	400	78
1050	3250	1350	1715	203	345	60	400	85

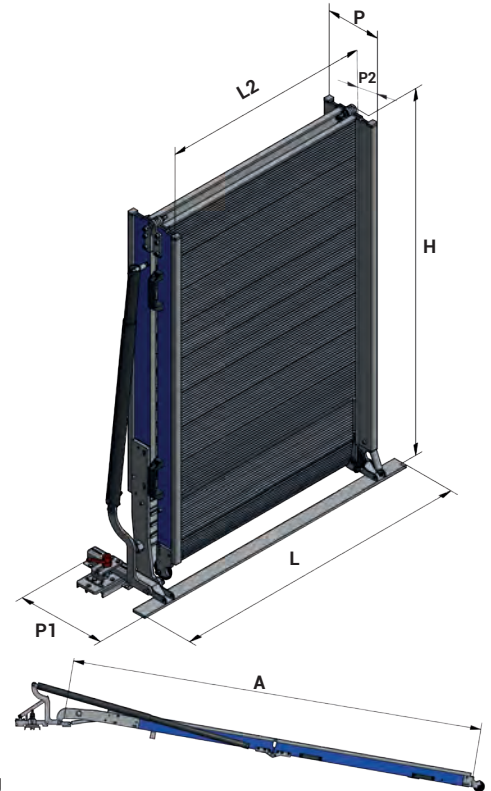

\* The specified weight does not include the installation kit, 5 kg. The external swivelling optional weighs +6 kg



# WM EASY

LOADING RAMP WITH LATERAL POSITIONING, AGILE AND EASY TO USE. LEAVES THE VAN'S CARGO AREA UNOBSTRUCTED AT ALL TIMES.



**LOAD CAPACITY**  
300 kg



**STANDARD DIMENSIONS**

Width 80 cm  
Length 200, 225, 250,  
275 and 300 cm



**HANDLING**

Swivel and Slide



**COLOUR**  
Yellow

LOAD CAPACITY: UP TO 300 KG



Anti-slip anodised aluminium perforated platform



Lateral positioning for minimum space requirements

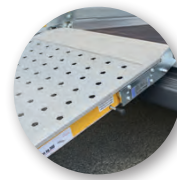

Safety edges

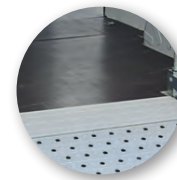

Flexible contact plate to the van floor

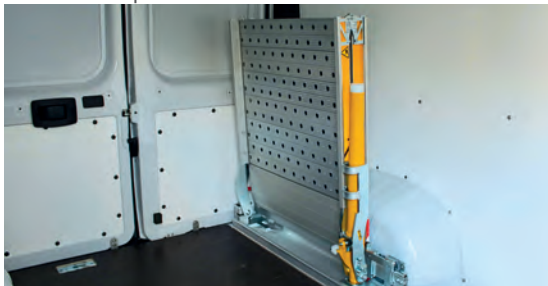



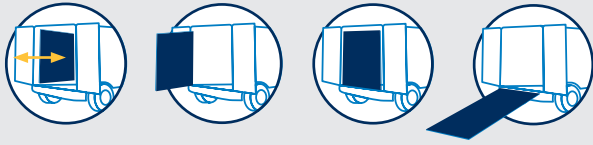

## DEPLOYMENT AND CLOSING

Designed with the evolving light commercial vehicle market in mind, the innovative WM EASY enhances our range. The EASY has the unique feature of being able to both swivel and slide out of the way as needed, leaving maximum space in the loading area. This ramp is popular with customers using side loading doors.

## OPTIONAL EXTRAS

### RIGHT-HAND VERSION



On request, the ramp can be mounted to the right-hand side of the van, inverting the swivel direction. It is also possible to open the ramp in the vertical direction, like a second door. This system makes it possible to gain access to the van's cargo area without using the ramp.

## APPLICATION SECTORS



MEDICAL  
AMBULANCES



MOBILITY  
PASSENGER  
TRANSPORT



COURIERS  
EQUIPMENT  
HIRE FIRMS

### UNOBSTRUCTED CARGO AREA:

- LATERAL POSITIONING
- ACCESS ALWAYS UNOBSTRUCTED
- NO OBSTACLES ON PLATFORM

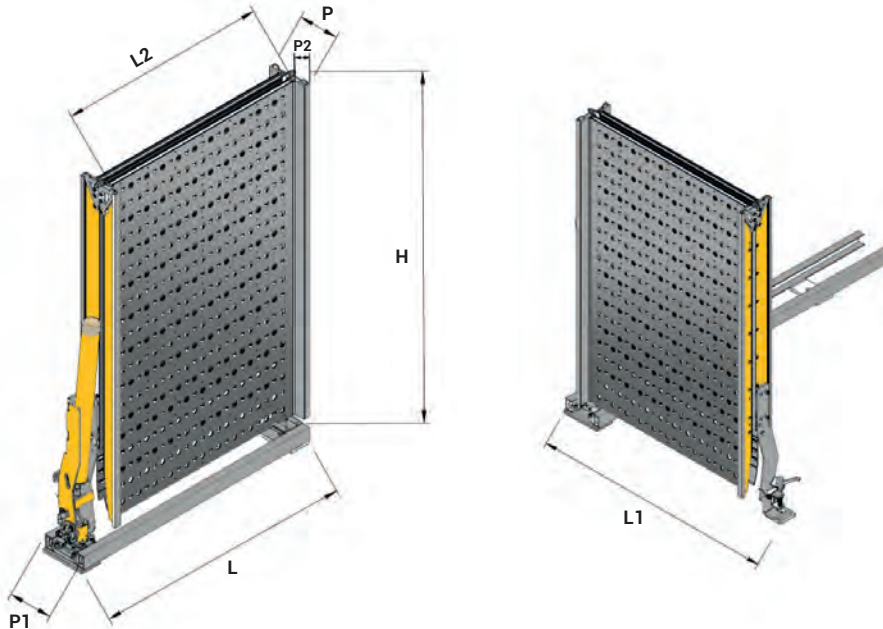
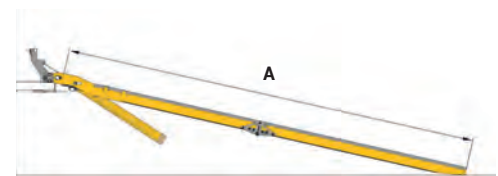

ALL MODELS	L2 (mm)	L (mm)	L1 (mm)	A (mm)	H (mm)	P (mm)	P1 (mm)	P2 (mm)	Capac. (kg)	Weight* (kg)
EASY	800	1170	1180	2000	1180	155	250	45	300	64
EASY	800	1170	1180	2250	1305	155	250	45	300	67
EASY	800	1170	1180	2500	1430	155	250	45	300	70
EASY	800	1170	1180	2750	1555	155	250	45	300	73
EASY	800	1170	1180	3000	1680	155	250	45	300	75

\* The specified weight includes the installation kit.

# WM READY

REMOVABLE, LIGHT-  
WEIGHT AND PRACTI-  
CAL LOADING RAMP  
NON-ANODISED ALU-  
MINUM PLATFORM.



**LOAD CAPACITY**  
300 kg

CUSTOM  
MINIMUM

## STANDARD DIMENSIONS

Width 80 cm  
Length 225, 250 e  
300 cm



**HANDLING**  
Removable



**COLOUR**  
Grey

LOAD CAPACITY: UP TO 300 KG



Aluminium anti-slip  
platform



Safety edges  
(4,5 cm)



Double gas strut for easy  
handling



Quick release and  
coupling



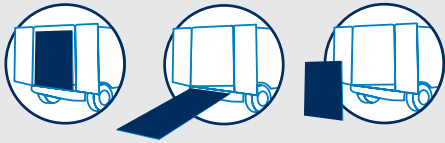

**REMOVABILITY AND TRANSPORT:** Quick release handles allow for easy removal of the ramp, leaving the load area unobstructed. The keyhole locating plates allow for easy and quick transfer between vehicles.

### OPTIONAL EXTRAS

#### FIXED INSTALLATION

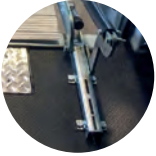

A fixed base can be mounted to the ramp on request. This means the ramp becomes fixed and can no longer be removed from the van. This solution simplifies and streamlines installation operations.

### APPLICATION SECTORS



ELECTRICIANS  
PLUMBING  
AND HEATING  
ENGINEERS



MULTIUTILITY



DISABLED  
USERS  
PASSENGER  
TRANSPORT

#### LOCKING HOOK:

• SAFE AND SIMPLE

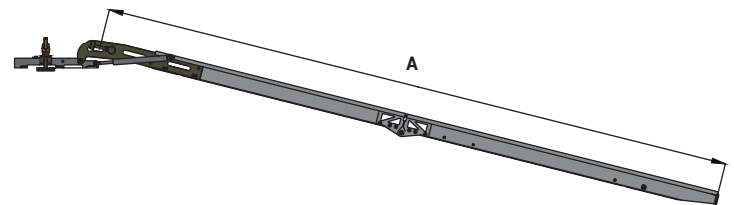
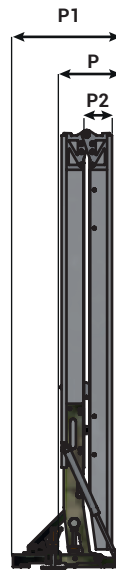
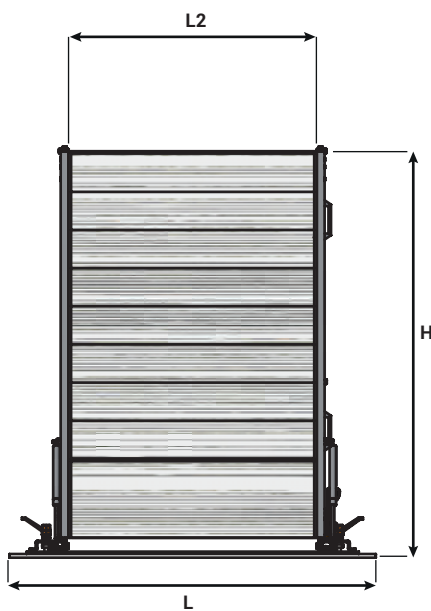

ALL MODELS	L2 (mm)	L (mm)	A (mm)	H (mm)	P (mm)	P1 (mm)	P2 (mm)	Capac. (Kg)	Weight* (Kg)
READY	800	1090	2250	1215	185	330	45	300	33
READY	800	1090	2500	1340	185	330	45	300	39
READY	800	1090	3000	1590	185	330	45	300	45

\* The specified weight does not include the installation kit, 2 kg.



# WM MOBILE

MOBILE LOADING RAMP. THE RAMP FOLDS INTO 2 SO IT CAN BE EASILY TRANSPORTED, AND IT FEATURES RESTON TYPE DESIGN SO IT DOES NOT REQUIRE ANY INSTALLATION OPERATIONS.



**LOAD CAPACITY**  
300 kg



**CUSTOMISED DIMENSIONS**  
Width from 30 to 100 cm  
Length from 150 to 325 cm



**HANDLING**  
Mobile



**COLOUR**  
Green

LOAD CAPACITY: UP TO 300 KG

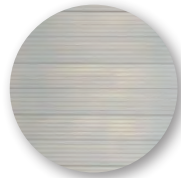

Aluminium anti-slip platform



Adjustable floor contact flap



Safety edges (5 cm)



Four wheels and two handles for easy transport





## REMOVABILITY AND TRANSPORT

Mobile ramp without installation requirements: simply rests on the van floor. The special rest-on system is adjustable and features 4 alternative positions for perfect adaptation to different vehicle heights.

## OPTIONAL EXTRAS



### ANODISED PLATFORM

For enhanced durability and aesthetics, the aluminium ramp can be supplied with an anodised surface treatment.

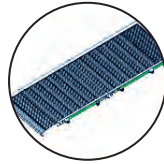

### ONE-PIECE RAMP

The central hinges can be locked to obtain a non-folding one-piece ramp.

## APPLICATION SECTORS



GENERAL  
CLEANING



ELECTRICIANS  
PLUMBING  
AND HEATING  
ENGINEERS



MOTORBIKES  
BICYCLES



EVENTS  
CONCERTS

## EXAMPLES OF POSSIBLE CONFIGURATIONS MODEL WM MOBILE

L2 (mm)	A (mm)	L1 (mm)	L (mm)	H (mm)	P (mm)	P2 (mm)	Capac. (kg)	Weight (kg)
400	1750	465	536	905	155	45	300	20,5
500	2250	565	636	1155	155	45	300	28,5
600	2500	665	736	1280	155	45	300	34,5
650	2750	715	786	1405	155	45	300	39,5
700	3000	765	836	1530	155	45	300	44,5
700	2000	765	836	1030	155	45	300	31,5
750	2500	815	886	1280	155	45	300	39,5
800	2000	865	936	1030	155	45	300	*27,5
800	2500	865	936	1280	155	45	300	*32,5
800	3000	865	936	1530	155	45	300	*38,5
800	3250	865	936	1655	155	45	300	52,5
850	2000	915	986	1030	155	45	300	36,5
900	3000	965	1036	1530	155	45	300	53,5
1000	2500	1065	1136	1280	155	45	300	48,5
1000	3000	1065	1136	1530	155	45	300	57,5

\* lightweight version

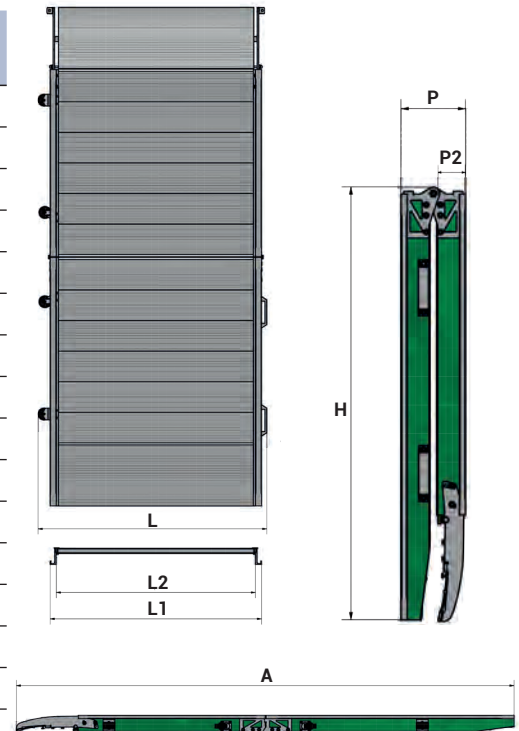



# WM TELESCOPIC

PRACTICAL, EASY  
TO USE MOBILE  
TELESCOPIC RAMP. IN  
PERFORATED ANTI-  
SLIP ALUMINIUM  
WITH SAFETY EDGES.



**LOAD CAPACITY**  
300 kg per pair



**STANDARD  
DIMENSIONS**  
Width 18.5 cm  
Length 150, 200, 225,  
250 and 300 cm



**HANDLING**  
Mobile



**COLOUR**  
Yellow

LOAD CAPACITY: UP TO 300 KG PER PAIR OF RAMPS

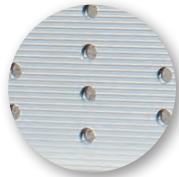

Anodised aluminium  
perforated platform



Adjustable floor  
contact flap

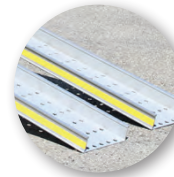

Safety edges  
(5.5 cm)



Transport  
handle





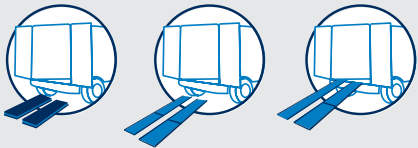

## REMOVABILITY AND TRANSPORT

The WM Telescopic is unique in the way it can be extended to the required length. This ramp offers a rest-on, folding contact plate for safe and secure loading. These can be supplied individually or as a pair as required.

## OPTIONAL EXTRAS



### ECO VERSION

ECO version also available: unperforated loading platform, without taper in the contact flap and without yellow colour on safety edges.

## APPLICATION SECTORS



DISABLED USERS  
PASSENGER  
TRANSPORT



MOTORBIKES  
BICYCLES



MEDICAL  
AMBULANCES

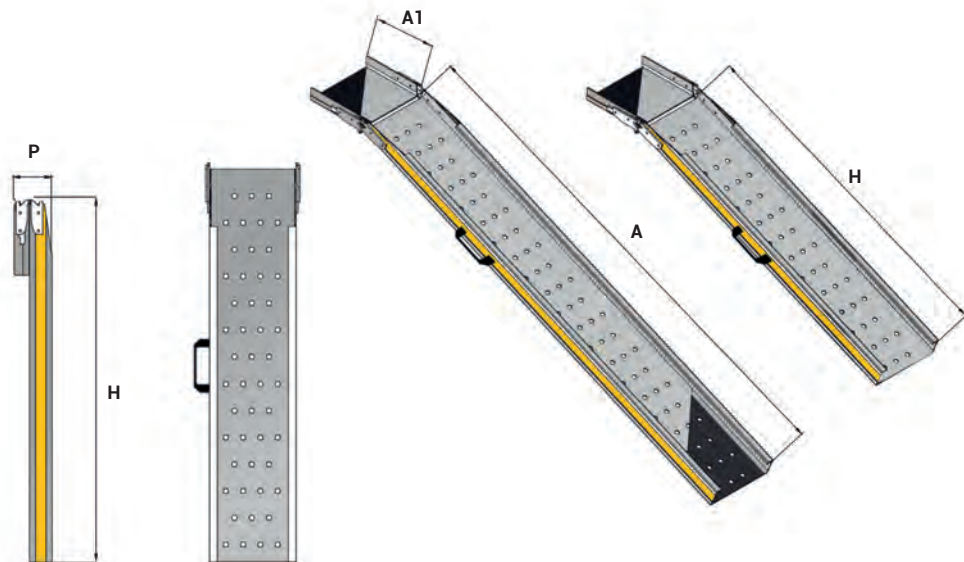

### CONTACT FLAP:

- TAPERED
- WITH 4 HEIGHT SETTINGS
- REST-ON (20 CM CONTACT LENGTH ON PLATFORM)
- FOLDING

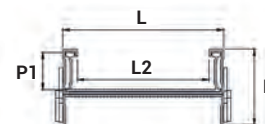

ALL MODELS	L2 (mm)	A1 (mm)	L (mm)	A (mm)	H (mm)	P (mm)	P1 (mm)	Load capacity per pair (kg)	Weight (kg)
WM TELESCOPIC	185	200	225	1500	900	106	55	300	5
WM TELESCOPIC	185	200	225	2000	1150	106	55	300	6
WM TELESCOPIC	185	200	225	2250	1275	106	55	300	6,5
WM TELESCOPIC	185	200	225	2500	1400	106	55	300	7
WM TELESCOPIC	185	200	225	3000	1650	106	55	300	8

# A RAMP FOR EVERY NEED









# A WORLD FULL OF SOLUTIONS



**WM SYSTEM S.r.l.**  
BUSINESS PREMISES - Via Campogrande 94/96  
REGISTERED OFFICE - Via 2 Giugno, 5  
42047 ROLO (Reggio Emilia) - ITALY  
Tel. +39 0522 665664 - Fax +39 0522 660327 - [info@wmsystem.com](mailto:info@wmsystem.com)

[www.wmsystem.com](http://www.wmsystem.com)

